

PCT

WORLD INTELLECTUAL PROPERTY ORGANIZATION
International Bureau



INTERNATIONAL APPLICATION PUBLISHED UNDER THE PATENT COOPERATION TREATY (PCT)

<p>(51) International Patent Classification ⁶ : A61M 11/00, 15/00, B65D 47/10</p>	<p>A1</p>	<p>(11) International Publication Number: WO 96/13291 (43) International Publication Date: 9 May 1996 (09.05.96)</p>
<p>(21) International Application Number: PCT/US95/13910 (22) International Filing Date: 27 October 1995 (27.10.95) (30) Priority Data: 08/331,047 28 October 1994 (28.10.94) US 08/508,982 28 July 1995 (28.07.95) US (71) Applicant: ARADIGM CORPORATION [US/US]; 26219 Eden Landing Road, Hayward, CA 94545 (US). (72) Inventors: LLOYD, Lester, J.; 7 Haciendas Road, Orinda, CA 94563 (US). LLOYD, Peter, M.; 6239 Elderberry Drive, Oakland, CA 94611 (US). RUBSAMEN, Reid, M.; 102 El Camino Real, Berkeley, CA 94705 (US). SCHUSTER, Jeffrey, A.; 5 El Portal Court, Berkeley, CA 94708 (US). (74) Agent: BOZICEVIC, Karl; Fish & Richardson P.C., Suite 100, 2200 Sand Hill Road, Menlo Park, CA 94025 (US).</p>	<p>(81) Designated States: AM, AT, AU, BB, BG, BR, BY, CA, CH, CN, CZ, DE, DK, EE, ES, FI, GB, GE, HU, IS, JP, KE, KG, KP, KR, KZ, LK, LR, LT, LU, LV, MD, MG, MN, MW, MX, NO, NZ, PL, PT, RO, RU, SD, SE, SG, SI, SK, TJ, TM, TT, UA, UG, UZ, VN, European patent (AT, BE, CH, DE, DK, ES, FR, GB, GR, IE, IT, LU, MC, NL, PT, SE), OAPI patent (BF, BJ, CF, CG, CI, CM, GA, GN, ML, MR, NE, SN, TD, TG), ARIPO patent (KE, LS, MW, SD, SZ, UG). Published <i>With international search report.</i></p>	

(54) Title: DEVICE FOR AEROSOLIZING NARCOTICS

(57) Abstract

Devices are hand-held, self-contained units which are automatically actuated at the same release point in a patient's inspiratory flow cycle. Actuation of the device forces an analgesic formulation (5) through a porous membrane (3) of the container (1) which membrane has pores having a diameter in the range of about 0.25 microns to 1.5 microns. The porous membrane is positioned in alignment with a surface of a channel

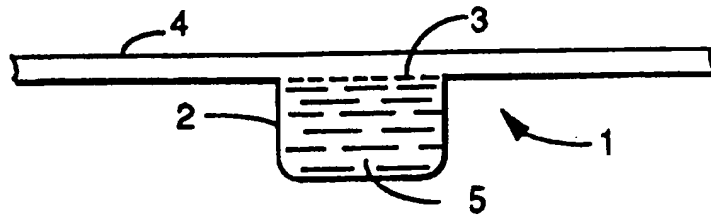

(11) through which a patient inhales air. The flow profile of air moving through the channel is such that the flow at the surface of the channel is less than the flow rate at the center of the channel. The membrane is designed so that it protrudes outward at all times or made flexible so that when an analgesic formulation is forced against and through the membrane, the flexible membrane protrudes outward beyond the flow boundary layer (13) of the channel into faster moving air.

FOR THE PURPOSES OF INFORMATION ONLY

Codes used to identify States party to the PCT on the front pages of pamphlets publishing international applications under the PCT.

AT	Austria	GB	United Kingdom	MR	Mauritania
AU	Australia	GE	Georgia	MW	Malawi
BB	Barbados	GN	Guinea	NE	Niger
BE	Belgium	GR	Greece	NL	Netherlands
BF	Burkina Faso	HU	Hungary	NO	Norway
BG	Bulgaria	IE	Ireland	NZ	New Zealand
BJ	Benin	IT	Italy	PL	Poland
BR	Brazil	JP	Japan	PT	Portugal
BY	Belarus	KE	Kenya	RO	Romania
CA	Canada	KG	Kyrgyzstan	RU	Russian Federation
CF	Central African Republic	KP	Democratic People's Republic of Korea	SD	Sudan
CG	Congo	KR	Republic of Korea	SE	Sweden
CH	Switzerland	KZ	Kazakhstan	SI	Slovenia
CI	Côte d'Ivoire	LI	Liechtenstein	SK	Slovakia
CM	Cameroon	LV	Latvia	SN	Senegal
CN	China	LK	Sri Lanka	TD	Chad
CS	Czechoslovakia	LU	Luxembourg	TG	Togo
CZ	Czech Republic	LV	Larvia	TJ	Tajikistan
DE	Germany	MC	Monaco	TT	Trinidad and Tobago
DK	Denmark	MD	Republic of Moldova	UA	Ukraine
ES	Spain	MG	Madagascar	US	United States of America
FI	Finland	ML	Mali	UZ	Uzbekistan
FR	France	MN	Mongolia	VN	Viet Nam
GA	Gabon				

- 1 -

DEVICE FOR AEROSOLIZING NARCOTICSField of the Invention

5 This invention relates generally to containers, devices and methods for aerosolizing formulation which is useful in methods of pain management involving the administration of narcotics. More specifically, this invention relates to containers and packaging used in a
10 hand-held, self-contained device capable of automatically releasing a controlled amount of narcotics to a patient at an optimal point in the respiratory cycle of the patient.

Background of the Invention

15 Narcotic therapy forms the mainstay of pain management. These drugs can be administered in many forms to patients with postsurgical and other forms of acute and chronic pain. Morphine, one of the oldest narcotics, is available for administration in tablet or in injectable form. Fentanyl, a synthetic narcotic, was first
20 synthesized in 1960 by Paul Janssen and found to be 150 times more potent than morphine [Theodore Stanley, "The History and Development of the Fentanyl Series," *Journal of Pain and Symptom Management* (1992) 7:3 (suppl.), S3-S7]. Fentanyl and its relatives Sufentanil and Alfentanil are
25 available for delivery by injection. In addition, fentanyl is available for administration by a transdermal delivery system in the form of a skin patch [Duragesic™ (fentanyl transdermal system) package insert, Janssen Pharmaceutica, Piscataway, NJ 08855, Jan-Jun 1991].

30 A feature of the synthetic narcotic fentanyl is that is has a more rapid time to onset and a shorter duration of action than morphine. This makes fentanyl a useful drug for the management of acute pain. Currently, fentanyl is typically given by intravenous injection for acute pain

- 2 -

management. Although fentanyl can be given by a transdermal patch, transdermal delivery of fentanyl is designed for long-term administration of the drug and does not lend itself to achieving a peak level rapidly for a short-term effect.

An alternative to delivery by injection for narcotics is delivery by inhalation. Morphine [J. Chrusbasik et al., "Absorption and Bioavailability of Nebulized Morphine," *Br. J. Anaesth.* (1988) 61, 228-30], fentanyl [M.H. Worsley et al., "Inhaled Fentanyl as a Method of Analgesia," *Anaesthesia* (1990) 45, 449-51], and sufentanil [A.B. Jaffe et al., "Rats Self-administer Sufentanil in Aerosol Form," *Psychopharmacology*, (1989) 99, 289-93] have been shown to be deliverable as aerosols into the lung. The pilot study described by Worsley suggested that "inhaled fentanyl is an effective, safe and convenient method of analgesia which merits further investigation."

Inhalation of a potent synthetic narcotic aerosol provides a mechanism for the non-invasive delivery of rapid-acting boluses of narcotic. The on-demand administration of boluses of narcotic coupled with a controlled baseline intravenous infusion of narcotic is termed "patient-controlled analgesia" (PCA) and has been

- 3 -

found to be a very effective means of postoperative pain management.

Demand analgesia was first introduced in 1968 by Schetzer who showed it to be an effective mechanism for treating postoperative patients [Maureen Smythe, "Patient-Controlled Analgesia: A Review," *Pharmacotherapy* (1992), 12:2, 132-43]. Prior to the availability of patient-controlled analgesia, the paradigm for postoperative pain management consisted of intermittent intramuscular injections of narcotic. The cycle of the patient felling pain, calling the nurse who then must locate and bring the drug to the bedside for administration results in suboptimal postoperative pain management [Philip Shade, "Patient-controlled Analgesia: Can Client Education Improve Outcomes?," *Journal of Advanced Nursing* (1992) 17, 408-13]. Postoperative pain management by intermittent narcotic administration has been shown to be a largely ineffective method of pain management for many of the patients undergoing the more than 21 million surgical procedures in the United States each year [John Camp, "Patient-Controlled Analgesia," *AFP* (1991), 2145-2150]. Even if every patient reliably received a constant dose of narcotic postoperatively, studies of therapeutic narcotic pharmacokinetic data have shown that patient variability makes such an approach fundamentally unsound and potentially dangerous [L.E. Mather, "Pharmacokinetics and Patient-Controlled Analgesia," *Acta Anaesthesiologica Belgica* (1992) 43:1, 5-20].

The first commercial device for automatically providing intravenous patient-controlled analgesia was developed in Wales in the mid-1970s. This device, the Cardiff Palliator (Graesby Medical Limited, United Kingdom) is the predecessor of numerous currently available computer-controlled patient-controlled analgesia intravenous pumps [Elizabeth Ryder, "All about Patient-

- 4 -

Controlled Analgesia," *Journal of Intravenous Nursing* (1991) 14, 372-81]. Studies using these computer controlled intravenous narcotic infusion pumps have shown that small doses of narcotics given on demand by the patient provided superior pain relief when compared with intermittent intramuscular administration of these drugs [Morton Rosenberg, "Patient-Controlled Analgesia," *J. Oral Maxillofac Surg* (1992) 50, 386-89].

These computer-controlled pumps typically allowed for the programming of four different parameters: 1) basal intravenous narcotic infusion rate; 2) the bolus of narcotic to be delivered on each patient demand; 3) the maximum hourly total dose of narcotic to be allowed; and 4) the lockout period between doses. Typical programming for postoperative pain management with intravenous fentanyl might be a basal infusion rate of 20 $\mu\text{g/hr}$, a bolus demand dose of 20 μg , a maximum hourly dose of 180 μg , and a lockout period between doses of 5 minutes. In a study of 30 patients treated for postoperative pain with intravenous fentanyl patient-controlled analgesia, the minimum effective concentration (MEC) of fentanyl in the blood required to achieve pain relief in the group of patients studied was found to range from 0.23 to 1.18 ng/ml. Clinically significant respiratory depression was not seen in this study consistent with published data indicating that a fentanyl concentration of 2 ng/ml in the blood is typically required to depress the respiratory rate [Geoffrey Gourlay et al., "Fentanyl Blood Concentration - Analgesic Response Relationship in the treatment of Postoperative Pain," *Anesth Analg* (1988) 67, 329-37].

The administration of narcotic for pain management is potentially dangerous because overdoses of narcotics will cause complications such as respiratory depression. The patient's respiratory rate is decreased by the Administration of narcotics. This decrease in respiratory

- 5 -

rate may not be associated with a change in respiratory tidal volume [Miller, *Anesthesia* (2nd ed), Churchill Livingstone, I, 762]. The four programmable parameters available on computer-controlled intravenous patient-controlled analgesia infusion pumps must be selected so as to minimize the likelihood of narcotic overdose. The preferred technique is to set the basal infusion rate at a relatively low rate and increase this rate based on how many times the patient presses the bolus demand button to self-administer supplemental drug.

As long as the patient himself or herself is the only one to push the demand button, respiratory depression is unlikely. However, there have been documented cases of the patient's family and friends pressing the narcotic demand button, for instance while the patient is sleeping [Robert Rapp et al., "Patient-controlled Analgesia: A Review of the Effectiveness of Therapy and an Evaluation of Currently Available Devices," *DICP, The Annals of Pharmacotherapy* (1989) 23, 899-9040].

It is a problem with patient-controlled analgesia that it must currently be performed using an intravenous infusion pump. This requires that an indwelling catheter be placed in the patient's vein and that the patient transport a relatively bulky system with himself at all times to receive a baseline infusion of intravenous narcotic and allow for intermittent on-demand self-bolusing of additional narcotic in order to match the patient's changing need for drug. A portable PCA device incorporating a wristwatch-like interface has been described [D.J. Rowbotham, "A Disposable Device for Patient-Controlled Analgesia with Fentanyl," *Anaesthesia* (1989) 44, 922-24]. This system incorporated some of the features of computer-controlled programmable PCA infusion pumps such as basal infusion rate and the amount of each bolus. However, this system, which involved the use of an

- 6 -

intravenous catheter as seen in larger infusion pumps, incorporated no provision to record accurately the actual dose of Fentanyl administered to the patient over time.

Although fentanyl can be administered by transdermal
5 patch, this method has been found to be suboptimal for postoperative pain management [K.A. Lehmann et al., "Transdermal Fentanyl for the Treatment of Pain after Major Urological Operations, *Eur. J. Clin Pharmacol* (1991) 21:17-21]. Lehmann found that the low dose of narcotic delivered
10 by transdermal fentanyl was inadequate to provide pain relief to many of his patients and that boosting the baseline infusion rate of the patch would put some patients at risk for having significant respiratory depression. In addition, he points out that if such a complication were to
15 appear in conjunction with the delivery of narcotic by transdermal patch, the infusion could not be quickly stopped because the "cutaneous fentanyl depot" created by the transdermal patch would cause narcotic infusion to continue even after removal of the patch.

20 Delivery of fentanyl by aerosol used in conjunction with a non-invasively delivered long-acting preparation of narcotic such as slow-release oral morphine or a fentanyl transdermal patch provides a means for non-invasive administration of a basal rate of narcotic and rapid-acting
25 boluses of narcotic to an ambulatory patient.

It is a problem with the aerosol delivery of fentanyl previously described that inefficient, bulky nebulizers must be used for the administration of the drug. In addition, these nebulizers work by administering from an
30 open reservoir of the drug in aqueous solution allowing the vapor to be generally distributed and creating the potential for overdosing due to the lack of reproducible aerosol delivery. In addition, abuse through theft of the aqueous-phase fentanyl and subsequent unauthorized

- 7 -

repackaging of this controlled substance in an aqueous injectable form are possible.

Because most surgery today is being done on ambulatory patients and because these patients are often rapidly discharged from the hospital and because patient-controlled analgesia has been identified as the preferred method of postoperative pain management, it is desirable to have a safe and effective method for non-invasive, ambulatory patient-controlled analgesia.

10 Summary of the Invention

Devices, packaging and methodology for efficiently and repeatably creating aerosolized bursts of an analgesic (e.g., narcotic) containing formulation are disclosed. Devices are hand-held, self-contained units which are automatically actuated at the same release point in a patient's inspiratory flow cycle. The release point is automatically determined either mechanically or, more preferably calculated by a microprocessor which receives data from a sensor making it possible to determine inspiratory flow rate and inspiratory volume. The device is loaded with a cassette comprised of an outer housing which holds a package of individual disposable collapsible containers of an analgesic containing formulation for systemic delivery. Actuation of the device forces analgesic formulation through a porous membrane of the container which membrane has pores having a diameter in the range of about 0.25 to 3.0 microns, preferably 0.25 to 1.5 microns. The porous membrane is positioned in alignment with a surface of a channel through which a patient inhales air. The flow profile of air moving through the channel is such that the flow at the surface of the channel is less than the flow rate at the center of the channel. The membrane is designed so that it protrudes outward at all times or made flexible so that when an analgesic

- 8 -

formulation is forced against and through the membrane the flexible membrane protrudes outward beyond the flow boundary layer of the channel into faster moving air. Because the membrane protrudes into the faster moving air of the channel the particles of aerosol formed are less likely to collide allowing for the formation of a burst of fine aerosol mist with uniform particle size.

Smaller particle sizes are preferred to obtain systemic delivery of analgesic. Thus, in one embodiment, after the aerosolized mist is released into the channel energy is actively added to the particles in an amount sufficient to evaporate carrier and thereby reduce particle size. The air drawn into the device is actively heated by moving the air through a heating material which material is pre-heated prior to the beginning of a patient's inhalation. The amount of energy added can be adjusted depending on factors such as the desired particle size, the amount of the carrier to be evaporated, the water vapor content of the surrounding air and the composition of the carrier.

To obtain systemic delivery it is desirable to get the aerosolized analgesic formulation deeply into the lung. This is obtained per the present invention, in part, by adjusting particle sizes. Particle diameter size is generally about twice the diameter of the pore from which the particle is extruded. In that it is technically difficult to make pores of 2.0 microns or less in diameter the use of evaporation can reduce particle size to 3.0 microns or less even with pore sizes well above 1.5 microns. Energy may be added in an amount sufficient to evaporate all or substantially all carrier and thereby provide particles of dry powdered analgesic or highly concentrated analgesic formulation to a patient which particles are uniform in size regardless of the surrounding humidity and smaller due to the evaporation of the carrier.

- 9 -

Air drawn into the device by the patient may be drawn through a desiccator containing a desiccant which removes moisture from the air thereby improving evaporation efficiency when the carrier is water. Alternatively, water vapor or aerosolized water may be introduced to the channel to saturate inhaled air thereby preventing evaporation of carrier and maintaining particle size. By adding energy some or all carrier can be evaporated. Alternatively, by adding water evaporation can be prevented. Either procedure provides a desired result in that the size of the particles may be modified or maintained regardless of the surrounding humidity of the air where the device is used.

In addition to adjusting particle size, systemic delivery of analgesic is obtained by releasing an aerosolized dose at a desired point. When providing systemic delivery it is important that the delivery be reproducible.

Reproducible dosing is obtained by providing for automatic release in response to real time determinations of both inspiratory rate and inspiratory volume. The method involves measuring for, determining and/or calculating a firing point or drug release decision based on instantaneously (or real time) calculated, measured and/or determined inspiratory flow rate and inspiratory volume points. To obtain repeatability in dosing the narcotic formulation is repeatedly released at the same measured (1) inspiratory flow rate and (2) inspiratory volume. To maximize the efficiency of the delivery the narcotic formulation is released at (1) a measured inspiratory flow rate in the range of from about 0.10 to about 2.0 liters/second and (2) a measured inspiratory volume in the range of about 0.15 to about 1.5 liters. Abuse of narcotic formulations is avoided by providing a tamper-resistant device which includes a variety of

- 10 -

security features including a pre-programmed microprocessor designed to avoid overdosing.

It is an object of this invention to describe a method of aerosolized delivery of potent narcotic in a safe and effective manner.

An advantage of the present invention is that it can be used for ambulatory patients.

A feature of the invention is that aerosolized potent narcotics can be used in conjunction with a non-invasively delivered baseline infusion rate of narcotic to provide a complete method for patient-controlled analgesia for ambulatory patients.

Another object is to provide a method of managing the pain of ambulatory patients wherein aerosolized narcotic formulation is repeatedly delivered to the patient at the same measured inspiratory volume (in the range of 0.15 to 1.5 liters) and the same measured inspiratory flow rate (in the range of 0.1 to 2.0 liters per sec).

It is another object of the invention to provide a metered-dose inhaler canister comprising a formulation of narcotic such as fentanyl packaged in a manner such that it can only be used in conjunction with a particular apparatus described.

Another advantage is that the device can be programmed to provide a minimum required time interval between doses.

Another advantage of the invention is that the device can be programmed so as to control the maximum amount of narcotic delivered within a period of time.

Still another advantage is that dosing of narcotics can be controlled so that aerosol delivery is possible and patients can obtain quick pain relief using such.

Yet another advantage is to provide a device which can be simultaneously programmed to control the maximum amount of narcotic drug delivered within a given period of

- 11 -

time and provide for a minimum required time interval between the delivery of doses.

A feature of the invention is that it can monitor the amount of aerosolized narcotic delivered to a patient and record amounts and times of delivery for review by a
5 treating physician.

Another advantage of the invention is that the apparatus can monitor respiratory rate to ensure that respiratory depression has not supervened prior to further
10 administration of narcotic.

Another object of this invention is to provide an apparatus which can analyze the breathing pattern of the patient not only to determine the respiratory rate prior to delivery but also to determine the inspiratory flow profile
15 characteristics so as to determine the optimal point in the inspiratory cycle for delivery of aerosolized potent narcotic.

Yet another object of this invention is to further provide aerosolized naloxone which may be administered to
20 counteract the effects of administered potent narcotic in the event of the development of complications such as respiratory depression due to overdose of the narcotic.

Another advantage is that the method described provides for reproducible delivery of narcotics such as
25 fentanyl wherein the reproducibility is a critical part of safety causing each dose of narcotic to have the same clinical effect.

Another object is to provide an electronic lock-and-key system which can ensure that only the intended
30 authorized patient can inhale aerosolized narcotic from the described apparatus making unauthorized users unable to inhale drug from the system.

An object of the invention is to provide a container which holds an aerosolizable formulation of analgesic which
35 container comprises a porous membrane which protrudes

- 12 -

outward in a stationary state or on the application of force forming a convex surface when drug formulation is forced against and through the membrane.

Another object is to provide a method for creating
5 an aerosol of analgesic formulation which comprises drawing air over a surface of a porous membrane in a channel and forcing formulation against the membrane so as to protrude the membrane through a flow boundary layer into faster moving air of the channel.

10 Another object of the invention is to adjust particle size by adding energy to the particles in an amount sufficient to evaporate carrier and reduce total particle size.

Another object is to provide a drug delivery device
15 which includes a desiccator for drying air in a manner so as to remove water vapor and thereby provide consistent particle sizes even when the surrounding humidity varies.

Another object is to provide a device for the delivery of aerosols which measures humidity via a solid
20 state hygrometer.

A feature of the invention is that drug can be dispersed or dissolved in a liquid carrier such as water and dispersed to a patient as dry or substantially dry particles.

25 Another advantage is that the size of the particles delivered will be independent of the surrounding humidity.

These and other objects, advantages and features of the present invention will become apparent to those skilled in the art upon reading this disclosure in combination with
30 drawings wherein like numerals refer to like components throughout.

- 13 -

Brief Description of the Drawings

Figure 1 is a cross-sectional view of a container of the invention;

Figure 2 is a cross-sectional view of a preferred embodiment of a container of the invention;

Figure 3 is a cross-sectional view of the container of Figure 2 in use in a channel of a drug delivery device;

Figure 4 is a plan view of a drug delivery device of the invention;

Figure 5 is a graph plotting the density of water vapor in air versus temperature;

Figure 6 is a graph plotting the density of ethanol vapor in air versus temperature;

Figure 7 is a perspective view of the package of the invention;

Figure 8 is a perspective view of a container of the invention;

Figure 9 is a graph showing data points plotted in four general areas with the points plotted relative to inspiratory flow rate (on the abscissa) and inspiratory volume (on the ordinate) in two dimensions;

Figure 10 is a graph showing the four general areas plotted per figure 1 now plotted with a third dimension to show the percentage of drug reaching the lungs based on a constant amount of drug released;

Figure 11 is a three dimensional graph showing the therapeutic values for inspiratory flow rate and inspiratory volume which provide better drug delivery efficiency;

Figure 12 shows a preferred range of the values shown in figure 7; and

Figure 13 shown a particularly preferred range for the values of figure 7.

- 14 -

Detailed Description of the Preferred Embodiments

Before the present method of pain management and containers, devices and formulations used in connection with such are described, it is to be understood that this invention is not limited to the particular methodology, containers, devices and formulations described, as such methods, containers, devices and formulations may, of course, vary. It is also to be understood that the terminology used herein is for the purpose of describing particular embodiments only, and is not intended to limit the scope of the present invention which will be limited only by the appended claims.

It must be noted that as used herein and in the appended claims, the singular forms "a," "an," and "the" include plural referents unless the context clearly dictates otherwise. Thus, for example, reference to "a formulation" includes mixtures of different formulations, reference to "an antagonist" includes a plurality of such compounds, and reference to "the method of treatment" includes reference to equivalent steps and methods known to those skilled in the art, and so forth.

Unless defined otherwise, all technical and scientific terms used herein have the same meaning as commonly understood by one of ordinary skill in the art to which this invention belongs. Although any methods and materials similar or equivalent to those described herein can be used in the practice or testing of the invention, the preferred methods and materials are now described. All documents mentioned herein are incorporated herein by reference to describe and disclose specific information for which the documents was cited in connection with.

The term "velocity of the drug" or "velocity of particles" shall mean the average speed of particles of respiratory drug formulation moving from a release point such as a porous membrane or a valve to a patient's mouth.

- 15 -

In a preferred embodiment the velocity of the particles is zero or substantially zero in the absence of flow created by patient inhalation.

The term "bulk flow rate" shall mean the average velocity at which air moves through a channel considering that the flow rate is at a maximum in the center of the channel and at a minimum at the inner surface of the channel.

The term "flow boundary layer" shall mean a set of points defining a layer above the inner surface of a channel through which air flows wherein the air flow rate below the boundary layer is substantially below the bulk flow rate, e.g., 50% or less than the bulk flow rate.

The term "carrier" shall mean a liquid, flowable, pharmaceutically acceptable excipient material which analgesic is suspended in or more preferably dissolved in. Useful carriers do not adversely interact with the analgesic and have properties which allow for the formation of aerosolized particles preferably particles having a diameter in the range of 0.5 to 3.0 microns when a formulation comprising the carrier and respiratory drug is forced through pores having a diameter of 0.25 to 3.0 microns. Preferred carriers include water, ethanol and mixtures thereof. Other carriers can be used provided that they can be formulated to create a suitable aerosol and do not adversely effect the analgesic on human lung tissue.

The term "measuring" describes an event whereby either the inspiratory flow rate or inspiratory volume of the patient is measured in order to determine an optimal point in the inspiratory cycle at which to release aerosolized drug. An actual measurement of both rate and volume may be made or the rate can be directly measured and the volume calculated based on the measured rate. It is also preferable to continue measuring inspiratory flow during and after any drug delivery and to record

- 16 -

inspiratory flow rate and volume before, during and after the release of drug. Such reading makes it possible to determine if drug was properly delivered to the patient.

The term "dosing event" shall be interpreted to mean the administration of analgesic drug to a patient in need thereof by the intrapulmonary route of administration which event may encompass one or more releases of analgesic drug formulation from an analgesic drug dispensing device over a period of time of 15 minutes or less, preferably 10 minutes or less, and more preferably 5 minutes or less, during which period multiple inhalations are made by the patient and multiple doses of analgesic drug are released and inhaled. A dosing event generally involves the administration of analgesic drug to the patient in an amount of about 1 μ g to about 100 mg in a single dosing event which may involve the release of from about 10 μ l to about 1000 ml of analgesic drug formulation from the device. In certain situations with very potent analgesic the drug can be present in nanogram amounts.

The term "monitoring" event shall mean measuring lung functions such as inspiratory flow, inspiratory flow rate, and/or inspiratory volume so that a patient's lung function as defined herein, can be evaluated before and/or after drug delivery thereby making it possible to evaluate the effect of narcotic delivery on the patient's lung function.

The term "inspiratory flow rate" shall mean a value of air flow determined, calculated and/or measured based on the speed of the air passing a given point in a measuring device assuming atmospheric pressure \pm 5% and a temperature in the range of about 10°C to 40°C.

The term "inspiratory flow" shall be interpreted to mean a value of air flow calculated based on the speed of the air passing a given point along with the volume of the air that has passed that point with the volume calculation

- 17 -

being based on integration of the flow rate data and assuming atmospheric pressure, $\pm 5\%$ and temperature in the range of about 10°C to about 40°C.

The term "inspiratory volume" shall mean a
5 determined, measured and/or calculated volume of air passing a given point into the lungs of a patient assuming atmospheric pressure $\pm 5\%$ and a temperature in the range of 10°C to 40°C.

The term "inspiratory flow profile" shall be
10 interpreted to mean data calculated in one or more events measuring inspiratory flow and cumulative volume, which profile can be used to determine a point within a patient's inspiratory cycle which is optimal for the release of drug to be delivered to a patient. An optimal point within the
15 inspiratory cycle for the release of drug is based, in part, on a point within the inspiratory cycle likely to result in the maximum delivery of drug and based, in part, on a point in the cycle most likely to result in the delivery of a reproducible amount of drug to the patient at
20 each release of drug. Repeatability of the amount delivered is the primary criterion and maximizing the amount delivered is an important but secondary criterion. Thus, a large number of different drug release points might be selected and provide for repeatability in dosing
25 provided the selected point is again selected for subsequent releases. To insure maximum drug delivery the point is selected within given parameters.

The term "analgesic drug" shall be interpreted to mean a drug for treating symptoms of pain. Analgesic drugs
30 may include one of: narcotics, nonsteroidal anti-inflammatory drugs and mixed agonist-antagonistic drugs such as butorphanol. Examples of useful narcotics drugs are described and disclosed within the Physicians Desk Reference and the Drug Evaluations Annual 1993, published
35 by the American Medical Association, both of which are

- 18 -

incorporated herein by reference. The invention encompasses the free acids, free bases, salts, hydrates in various formulations of analgesic drugs useful for pain control.

5 The terms "formulation" and "liquid formulation" and the like are used interchangeably herein to describe any pharmaceutically active analgesic drug with a pharmaceutically acceptable carrier in flowable liquid form having properties such that it can be aerosolized to
10 particles having a diameter of 0.5 to 12.0 microns. Such formulations are preferably solutions, e.g. aqueous solutions, ethanolic solutions, aqueous/ethanolic solutions, saline solutions, colloidal suspensions or microcrystalline suspension. Formulations can be solutions
15 or suspensions of drug in a low boiling point propellant. Preferred formulations are drug(s) dissolved in water.

 The term "therapeutic index" refers to the therapeutic index of a drug defined as LD_{50}/ED_{50} . The LD_{50} (lethal dose, 50%) is defined as the dose of a drug which
20 kills 50% of the tested animals, and the ED_{50} is defined as the effective dose of the drug for 50% of the individuals treated. Drugs with a therapeutic index near unity (i.e. LD_{50}/ED_{50} is approximately equal to 1) achieve their therapeutic effect at doses very close to the toxic level
25 and as such have a narrow therapeutic window, i.e. a narrow dose range over which they may be administered.

 The term "substantially dry" shall mean that particles of formulation including an amount of carrier (e.g. water or ethanol) which is equal to (in weight) or
30 less than the amount of drug in the particle. Preferable such particles consist essentially of only analgesic drug with no free carrier e.g., no free water.

 The terms "aerosolized particles" and "aerosolized particles of formulation" shall mean particles of
35 formulation comprised of pharmaceutically active analgesic

- 19 -

drug and carrier which are formed upon forcing the formulation through a nozzle which nozzle is preferably in the form of a flexible porous membrane. The particles have a size which is sufficiently small such that when the particles are formed they remain suspended in the air for a sufficient amount of time such that the patient can inhale the particles into the patient's lungs. Preferably, the particles have a size in the range of 0.5 micron to about 12 microns having been created by being forced through the pores of a flexible porous membrane which pores have a diameter in the range of about 0.25 micron to about 6.0 microns -- the pores being present on the membrane in an amount of about ten to 10,000 pores over an area in size of from about 1 sq. millimeter to about 1 sq. centimeter.

The terms "lung function" and "pulmonary function" are used interchangeably and shall be interpreted to mean physically measurable operations of a lung including but not limited to (1) inspiratory and (2) expiratory flow rates as well as (3) lung volume. Methods of quantitatively determining pulmonary function are used to measure lung function. Quantitative determination of pulmonary function may be important when delivering analgesic drugs in that respiration can be hindered or stopped by the overdose of such drugs. Methods of measuring pulmonary function most commonly employed in clinical practice involve timed measurement of inspiratory and expiratory maneuvers to measure specific parameters. For example, forced vital capacity (FVC) measures the total volume in liters exhaled by a patient forcefully from a deep initial inspiration. This parameter, when evaluated in conjunction with the forced expired volume in one second (FEV_1), allows bronchoconstriction to be quantitatively evaluated. A problem with forced vital capacity determination is that the forced vital capacity maneuver (i.e. forced exhalation from maximum inspiration to maximum

- 20 -

expiration) is largely technique dependent. In other words, a given patient may produce different FVC values during a sequence of consecutive FVC maneuvers. The FEF₂₅₋₇₅ or forced expiratory flow determined over the mid-
5 portion of a forced exhalation maneuver tends to be less technique dependent than the FVC. Similarly, the FEV₁ tends to be less technique dependent than FVC. In addition to measuring volumes of exhaled air as indices of pulmonary function, the flow in liters per minute measured over
10 differing portions of the expiratory cycle can be useful in determining the status of a patient's pulmonary function. In particular, the peak expiratory flow, taken as the highest air flow rate in liters per minute during a forced maximal exhalation, is well correlated with overall
15 pulmonary function in a patient with asthma and other respiratory diseases. The present invention carries out treatment by administering drug in a drug delivery event and monitoring lung function in a monitoring event. A series of such events may be carried out and repeated over
20 time to determine if lung function is improved.

Each of the parameters discussed above is measured during quantitative spirometry. A patient's individual performance can be compared against his personal best data, individual indices can be compared with each other for an
25 individual patient (e.g. FEV₁ divided by FVC, producing a dimensionless index useful in assessing the severity of acute asthma symptoms), or each of these indices can be compared against an expected value. Expected values for indices derived from quantitative spirometry are calculated
30 as a function of the patient's sex, height, weight and age. For instance, standards exist for the calculation of expected indices and these are frequently reported along with the actual parameters derived for an individual patient during a monitoring event such as a quantitative
35 spirometry test.

- 21 -

Parameters For Delivery

In addition to adjusting delivery of an aerosolized burst of analgesic drug based on specific information on the patient such as the patient's sex, height, weight and
5 age a number of specific factors should be taken into consideration. Specifically, when determining the release point one should adjust:

(1) the release point within a patient's inspiratory flow rate inside a range of about 0.10 to about
10 2.0 liters/second preferably about 0.2 to about 1.8 liters per sec. and more preferably 0.15 to 1.7 liters per sec;

(2) the release point within a patient's inspiratory volume of about 0.15 to about 2.0 liters preferably 0.15 to 0.8 liters and more preferably 0.15 to
15 about 0.4 liters;

(3) particle size for systemic delivery in a range of about 0.5 to 6 microns and more preferably 0.5 to about 3 microns;

(4) the concentration of the drug in the carrier in
20 the range of from about 0.01% to about 12.5% ;

(5) the amount of heat added to the air about 20 Joules to about 100 Joules and preferably 20 Joules to about 50 Joules per 10 μ l of formulation;

(6) the relative volume of air added by patient
25 inhalation per 10 μ l of formulation at about 100 ml to 2 l and preferably about 200 ml to 1 liter for evaporation and without evaporation 50-750 ml preferably 200-400 ml;

(7) the rate of vibration of the porous membrane from 575 to 17,000 kilohertz;

30 (8) pore size to a range of about 0.25 to about 6.0 microns in diameter preferably 0.5 to 3 microns and more preferably 1-2 microns;

(9) viscosity of the formulation to a range of from about 25% to 1,000% of the viscosity of water;

- 22 -

(10) extrusion pressure in a range of about 50 to 600 psi and preferably 100 to 500 psi;

(11) ambient temperature to 15°C to 30°C and ambient pressure between 1 atmosphere and 75% of 1 atmosphere;

5 (12) the ratio of liquid carriers to each other to be consistent;

(13) the solubility of drug to carrier to obtain a high concentration of analgesic in the carrier;

10 (14) the desiccator to maximize removal of water vapor from air;

(15) the shape of the pore opening to be circular in diameter and a conical in cross-section with the ratio of the diameter of the small to large end of the cone being about $\frac{1}{2}$ to $\frac{1}{20}$, and the shape of the porous membrane to an elongated oval;

(16) the thickness of the membrane to 5 to 200 microns; preferably 10 - 50 microns;

20 (17) the membrane to have a convex shape or to be flexible so that it protrudes outward in a convex shape beyond the flow boundary layer when formulation is forced through it. and

25 (18) the firing point to be at substantially the same point at each release for the parameters (1-17), i.e., each release of drug is at substantially the same point so as to obtain repeatability of dosing.

General Methodology

30 A non-invasive means of pain management is provided in a manner which makes it possible to maintain tight control over the amount of drug administered to a patient suffering with pain and to quickly and efficiently provide for pain relief. An essential feature of the invention is the intrapulmonary delivery of analgesic drug to the patient in a controlled and repeatable manner. The device of the invention provides a number of features which make

- 23 -

it possible to achieve the controlled and repeatable dosing procedure required for pain management. Specific parameters are pointed out above and it is noted that the device is not directly actuated by the patient in the sense that no button is pushed nor valve released by the patient applying physical pressure. The method preferably provides that analgesic drug is released automatically upon receipt of a signal from a microprocessor programmed to send a signal when data is received from a monitoring device such as an airflow rate monitoring device. A patient using the device withdraws air from a mouthpiece and the inspiratory rate, and calculated inspiratory volume of the patient are measured one or more times in a monitoring event which determines a preferred point in an inhalation cycle for the release of a dose of analgesic drug. Inspiratory flow is measured and recorded in one or more monitoring events for a given patient in order to develop an inspiratory flow profile for the patient. The recorded information is analyzed by the microprocessor in order to deduce a preferred point within the patient's inspiratory cycle for the release of analgesic drug with the preferred point being calculated based on the most likely point to result in a reproducible delivery event.

It is pointed out that the device of the present invention can be used to, and actually does, improve the efficiency of drug delivery. However, this is a secondary feature. The primary feature is the reproducibility of the release of a tightly controlled amount of analgesic drug at a particular point in the respiratory cycle so as to assure the delivery of a controlled and repeatable amount of analgesic to the lungs of each individual patient in a manner which allows for systemic delivery.

The combination of automatic control of the valve release, combined with frequent monitoring events in order to calculate the optimal flow rate and time for the release

- 24 -

of analgesic drug, combine to provide a repeatable means of delivering analgesic drug to a patient. Because the valve is released automatically and not manually, it can be predictably and repeatedly opened for the same amount of
5 time each time or for the preprogrammed measured amount of time which is desired at that particular dosing event. Because dosing events are preferably preceded by monitoring events, the amount of analgesic drug released and/or the point in the inspiratory cycle of the release can be
10 readjusted based on the particular condition of the patient. For example, if the patient is suffering from a condition which allows for a certain degree of pulmonary insufficiency, such will be taken into account in the monitoring event by the microprocessor which will readjust
15 the amount and/or point of release of the analgesic drug in a manner calculated to provide for the administration of the same amount of analgesic drug to the patient at each dosing event.

Drug Delivery with Disposable Container

20 Figure 1 is a cross-sectional view of a container 1 of the invention which is shaped by a collapsible wall 2. The container 1 has an opening covered by a flexible porous membrane 3 which is covered by a removable layer 4. The membrane 3 may be rigid and protrude upward in a convex
25 configuration away from the formulation 5. When the layer 4 is removed the wall 2 can be collapsed thereby forcing the analgesic formulation 5 against the flexible porous membrane 3 which will then protrude outward in a convex shape.

30 Figure 2 is a cross-sectional view of a more preferred embodiment of a container 1 of the invention. The container is shaped by a collapsible wall 2. The container 1 includes an opening which leads to an open channel 6 which channel 6 includes an abutment 7 which is

- 25 -

broken upon the application of force created by formulation 5 being forced from the container. When the abutment 7 is broken the formulation 5 flows to an area adjacent to the flexible porous membrane 3 and is prevented from flowing 5 further in the channel 6 by a non-breakable abutment 8.

Figure 3 is a cross-sectional view of the container 1 of Figure 2 in use. The wall 2 is being crushed by a mechanical component such as the piston 9 shown in Figure 3. The piston may be driven by a spring, compressed gas, 10 or a motor connected to gears which translate the electric motor's circle motion to linear motion. The formulation 5 is forced into the open channel 6 (breaking the abutment 7 shown in Figure 2) and against and through the membrane 3 causing the membrane 3 to protrude outward into a convex 15 configuration as shown in Figure 3.

The piston 9 has been forced against the container wall 2 after a patient 10 begins inhalation in the direction of the arrow "I". The patient 10 inhales through the mouth from a tubular channel 11. The velocity of the 20 air moving through the flow path 29 of the channel 11 can be measured across the diameter of the channel to determine a flow profile 12, i.e., the air flowing through the channel 11 has a higher velocity further away from the inner surface of the channel. The air velocity right next 25 to the inner surface of the channel 11 (i.e., infinitely close to the surface) is very slow (i.e., approaches zero). A flow boundary layer 13 defines a set of points below which (in a direction from the channel center toward the inner surface of the channel) the flow of air is 30 substantially below the bulk flow rate i.e., 50% or less than the bulk flow rate.

To allow air to flow freely through the channel 11 the upper surface of the flexible porous membrane 3 is substantially flush with (i.e., in substantially the same 35 plane as) the inner surface of the channel 11. Thus, if

- 26 -

the membrane 3 remained in place when the formulation 5 move through the pores the formulation would be released into the slow moving or substantially "dead air" below the boundary layer 13. However, the membrane 3 protrudes 5 outward through the boundary layer 13 into the faster moving air. This is desirable in that it aids in avoiding the agglomulation of particles. More specifically, when formulation exits the pores the formulation naturally forms spherical particles. Those particles slow down due to the 10 frictional resistance created by the air through which the particles must travel. The particles existing behind them can face reduced air friction because the preceding particle have moved the air aside. Thus later released particles catch up with and merge into the earlier released 15 particles. This can cause a chain reaction resulting in the formation of large particles which can not be readily inhaled into the lung - e.g., the formation of particles having a diameter of more than about 12.0 microns.

A plan view of a simple embodiment of a drug 20 delivery device 40 of the present invention is shown within Figure 4. The device 40 is loaded and operates with a plurality of interconnected disposable containers 1 which form a package 46. Before describing the details of the individual components of the device 40, a general 25 description of the device and its operation is in order.

Conventional metered dose inhalers and nebulizers suffer from a number of disadvantages. These disadvantages result in the inability to use these devices to repeatedly deliver the same amount of drug to a patient. The 30 disadvantages are due, in part, to the inability to control particle size - especially when the device is used in diverse environments with greatly different humidity conditions or when differing amounts of drug are delivered into a fixed amount of air or similar quantities of drug 35 are delivered into differing amounts of air. By adding

- 27 -

sufficient energy to the particles to evaporate any carrier particle size is reduced to a uniform minimum and any humidity variations do not affect particle variability. Further the drug dispensing device of the present invention preferably includes electronic and/or mechanical components which eliminate direct user actuation of drug release. More specifically, the device preferably includes a means for measuring inspiratory flow rate and inspiratory volume and sending an electrical signal as a result of the simultaneous measurement of both (so that drug can be released at the same point each time) and also preferably includes a microprocessor which is programmed to receive, process, analyze and store the electrical signal of the means for measuring flow and upon receipt of signal values within appropriate limits sending an actuation signal to the mechanical means which causes drug to be extruded from the pores of the porous membrane.

The device 40 shown in Figure 4 is loaded with a disposable package 46. To use the device 40 a patient (see Figure 3) inhales air from the mouthpiece 30. The air drawn in through the opening 38 (and optionally the desiccator 41) flows through the flow path 29 of the channel 11. The disposable package 46 is comprised of a plurality of disposable containers 1. Each container 1 includes a drug formulation 5 and is covered by the porous membrane 3. An air-heating mechanism 14 located in the flow path 29. The air heating mechanism 14 is preferably positioned such that all or only a portion of the air flowing through the path 29 will pass by the heater, e.g., flow vent flaps can direct any desired portion of air through the heater 14. The heat is preferably turned on for 30 sec or less prior to inhalation and turned off after drug delivery to conserve power.

The device 40 is a hand-held, portable device which is comprised of (a) a device for holding a disposable

- 28 -

package with at least one but preferably a number of drug containers, and (b) a mechanical mechanism for forcing the contents of a container (on the package) through a porous membrane. The device preferably further includes (c) a heating mechanism for adding energy to the air flow into which particles are released, (d) a monitor for analyzing the inspiratory flow of a patient, (e) a switch for automatically releasing or firing the mechanical means after the inspiratory flow rate and/or volume reaches a predetermined point (f) a means for measuring ambient temperature and humidity and (g) a source of power e.g., conventional batteries.

The device for holding the disposable package may be nothing more than a narrow opening created between two outwardly extending bars 42 and 82 or may include additional components such as one or more wheels, sprockets or rollers notably mounted on the end(s) of such bars. The rollers may be spring mounted so as to provide constant pressure against the surface(s) of the package. The device may also include a transport mechanism which may include providing drive power to the roller(s) so that when they are rotated, they move the package from one container to the next. The power source 43 driving the roller(s) is programmed via the microprocessor 26 to rotate the rollers only enough to move the package 39 from one container 1 to the next. In order to use the device 40, the device 40 must be "loaded," i.e. connected to a package 39 which includes drug dosage units having liquid, flowable formulations of pharmaceutically active analgesic therein. The entire device 40 is self-contained, light weight (less than 1 kg preferably less than 0.5 kg loaded) and portable. The power source 43 is preferably in the form of standard alkaline batteries. Two 9 volt batteries could supply the heat required to heat the air which contacts the particles

- 29 -

by about 20°C for about 100 doses (see Figures 5 and 6 re energy required).

The formulation is preferably heated after the formulation has been forced through the pores of the membrane 3 and aerosolized i.e., energy is preferably added by heating the surrounding air by means of the air-heating mechanism 14 positioned anywhere within the flow path 29. The amount of energy added by the formulation heating mechanism 45 or air-heating mechanism 5 is controlled by the microprocessor 26 based on the amount of formulation in the container 1 and other factors such as the concentration of the analgesic in the formulation and surrounding humidity. A hygrometer 50 and thermometer 51 are electrically connected to the microprocessor 26 allowing the amount of heat to be added to be adjusted based on ambient humidity and temperature.

Potent drugs which are highly soluble in water, ethanol and/or mixtures thereof are particularly useful with the present invention in that such drugs can be used. The carrier may be chosen to provide for greater solubility of analgesic in the carrier to obtain a high concentration of analgesic and thus require less energy to obtain evaporation of the carrier. For example, a prescribed dose of Fentanyl (a highly potent narcotic) is 100 micrograms and such can be dissolved in 10 microliters of water. Particles having a diameter of 6.3 microns can be formed and subjected to evaporation to obtain a particle of one micron in diameter. In the respiratory track this one micron particle would be expected to grow to a 3 micron particle due to moisture added from the high humidity environment of the respiratory tract.

- 30 -

Energy For Evaporation

Figure 5 is a graph which can be used in calculating the amount of energy needed to control the size of delivered droplets by controlling the amount of evaporation of carrier from the aerosolized droplets. The graph of Figure 5 contains two types of information, the density of evaporated water vs. temperature and relative humidity, and the cooling of the air as the water evaporates. The four lines that show a rapid increase with temperature portray the density of water vapor in air, at 25, 50, 75, and 100% relative humidity. The 100% relative humidity curve represents the maximum number of milligrams of water that can be evaporated per liter of air. The diagonal lines show the temperature change of the air as the water droplets evaporate (hereafter called the air mass trajectory curves). As the evaporation proceeds, the density and temperature will change by moving parallel to these curves. To calculate these curves, air density of 1.185 grams/liter, air specific heat of .2401 calories/gram, and water latent heat of vaporization of 0.583 cal/mg were assumed. These values imply that a liter of air will cool 2 celsius degrees for every milligram of water evaporated, i.e. evaporating 10 micro-liters will cool a liter of air 20 celsius degrees.

Figure 5 can be used to calculate the amount of preheating needed to evaporate all or substantially all of the carrier in the aerosolized particles. As an example, assume the initial ambient conditions are 25°C and 50% relative humidity. Further, assume that one wants to evaporate 10 μ l (10mgs) of water from an aqueous drug solution. Finally, assume the final relative humidity is 75%. Under these conditions the aqueous carrier would not evaporate completely. More specifically, the final particles would contain approximately equal amounts of drug and water. To calculate the amount of energy to add for

- 31 -

this delivery manoeuver, refer to Figure 5. Locate the point corresponding to 25°C and 50% relative humidity. Move up by 10 milligrams, the amount of water to be evaporated. Now move to the left until the 75% RH curve is
5 crossed. This occurs at about 29°C. These conditions (75% RH and 29°C) represent the condition of the air as delivered to the patient. However, still more energy must be added to make up for the cooling of the air as the water evaporates. To calculate this amount of heat, move
10 parallel to the air mass trajectory curves (downward and to the right) until the initial ambient water vapor density is reached, at approximately 47°C. Thus, sufficient heat to warm the air by 22°C must be added to achieve near complete evaporation.

15 Figure 6 includes similar information with respect to ethanol which can be used in a similar manner. Figure 5 shows the density of water vapor in air at 25, 50 and 75°C and 100% saturation with the air mass trajectory during evaporation also shown. The same is shown in Figure 6 for
20 the density of ethanol in air.

The evaporation and growth rates of aqueous droplets is a function of their initial diameter, the amount of drug dissolved therein (concentration) and the ambient relative humidity. The determining factor is whether the water
25 vapor concentration at the surface of the droplet is higher or lower than that of the surrounding air. Because the relative humidity at the surface of a particle (i.e. droplet of aerosolized formulation) is close to 100% for all the high concentration formulations, a five micron
30 droplet will evaporate to a 1 micron dry particle in 0% humidity in less than 20 ms. However, if a particle of drug 1 micron diameter is inhaled into the lungs (99.5% humidity) it will grow to about 3 microns in diameter in approximately one second by accumulating water from the
35 humid lung environment.

- 32 -

Desiccator

The opening 38 may have a desiccator 41 positioned therein which desiccator includes a material which removes water vapor from air being drawn into the flow path 29. By 5 reducing or more preferably eliminating water vapor from the air any water in particles of formulation can be more efficiently evaporated. Further, the particles delivered to the patient will have a smaller and more uniform size even if energy is not added to cause evaporation of water 10 from the particles of the formulation.

The device may include a mouth piece 30 at the end of the flow path 29. The patient inhales from the mouth piece 30 which causes an inspiratory flow to be measured by flow sensor 31 within the flow path which path may be, and 15 preferably is, in a non-linear flow-pressure relationship. This inspiratory flow causes an air flow transducer 37 to generate a signal. This signal is conveyed to a microprocessor which is able to convert, continuously, the signal from the transducer 37 in the inspiratory flow path 20 29 to a flow rate in liters per minute. The microprocessor 26 can further integrate this continuous air flow rate signal into a representation of cumulative inspiratory volume. At an appropriate point in the inspiratory cycle, the microprocessor can send a signal to send power from the 25 power source 43 to the air-heating mechanism 14 which uses information from the hygrometer 50, thermometer 51 and particle size and amount of formulation. The microprocessor also sends a signal to an actuator which causes the mechanical means (e.g., the piston 24) to force 30 drug from a container of the package into the inspiratory flow path 29 of the device and ultimately into the patient's lungs. After being released, the drug and carrier will pass through a porous membrane 3 to aerosolize the formulation and thereafter enter the lungs of the 35 patient.

- 33 -

When the formulation 5 includes water as all or part of the carrier it is also desirable to include a desiccator 41 within the flow path 29. The desiccator 41 is preferably located at the initial opening 38 but maybe 5 located elsewhere in the flow path 29 prior to a point in the flow path when the formulation is fired into the flow path in the form of aerosolized particles. By drawing air through the desiccator 41 water vapor within the air is removed in part or completely. Therefore, only dried air 10 is drawn into the remainder of a flow path. Since the air is completely dried water carrier within the aerosolized particles will more readily evaporate. This decreases the energy needs with respect to the heating devices 14. The desiccator material can be any compound which absorbs water 15 vapor from air. For example, it may be a compound selected from the group consisting of P_2O_5 , $Mg(ClO_4)$, KOH , H_2SO_4 , $NaOH$, CaO , $CaCl_2$, $ZnCl_2$, and $CaSO_4$.

Flow/Volume Parameters

Figure 9 is a two-dimensional graph wherein the 20 inspiratory flow rate is plotted against the inspiratory volume. The patient's inspiratory flow rate and inspiratory volume may be simultaneously and separately determined, e.g., measured. The measurement is taken and the information obtained from the measurement provided to 25 a microprocessor which microprocessor is programmed to release analgesic drug (1) at the same point relative to inspiratory flow and inspiratory volume at each release of drug and (2) to select that point within prescribed parameters of inspiratory flow rates and inspiratory 30 volumes. In the particular results plotted in figure 9 the microprocessor was programmed to release drug in four general areas with respect to the inspiratory flow rate and inspiratory volume parameters. This resulted in data points being plotted in four general areas on the two-

- 34 -

dimensional graph of figure 9. The four areas are labeled A, B, C and D. In area A (showing solid triangles), the drug was released when the patient's inspiratory flow rate was "slow to medium" (0.10 to 2.0 liters per sec) with an
5 "early" inspiratory volume of 0.15 to 0.8 liters. In area B (showing open triangles), the drug was released at a "slow" inspiratory rate/0.10 to 1.0 liters/sec) and a "late" volume (1.6 to 2.8 liters). In area C (showing solid diamonds), the drug was released at a "fast"
10 inspiratory flow rate (3.5 to 4.5 liters/sec) and a "late" volume. In area D (showing solid circles), the drug was released at a "fast inspiratory flow rate and an "early" inspiratory volume.

The results shown in figure 9 were obtained while
15 administering a radioactively labeled drug to a human. After the administration of the drug it was possible to determine not only the amount of drug, but the pattern of drug deposited within the lungs of the patient. Using this information two conclusions were reached. Firstly, it was
20 determined that it is important to simultaneously and separately consider (in real time) both inspiratory flow rate and inspiratory volume when determining the point for drug release for intrapulmonary drug delivery. Changes in either parameter can greatly effect the amount of drug
25 deposited. Thus, when treating a patient the drug should be released at approximately ($\pm 10\%$, preferably $\pm 5\%$ and most preferable as close as possible to the first release point) the same inspiratory flow rate and inspiratory volume each time - going back to the same point each time for the same
30 patient ensures repeatable dosing. In practice the tighter the point is defined the greater the repeatability of dosing. However, if the point is defined to precisely it can be difficult for the patient to obtain that rate/volume point again. Thus, some degree of tolerance is generally
35 applied. Secondly, it was found that within particular

- 35 -

ranges with respect to inspiratory flow rate and inspiratory volume it was possible to obtain a consistently high percentage amount of drug deposited in the lung. Such results are shown graphically within the three dimensional graph as shown in figure 10.

The third dimension as shown in figure 10 (the height of the four columns) indicates the percentage amount of drug deposited based on the total amount of drug released to the patient. The area labeled A clearly showed the highest percentage of drug delivered to the patient based on the amount of drug released. Using this information it was possible to calculate a specific area regarding inspiratory flow rate and inspiratory volume at which it is possible to obtain not only a high degree of repeatability in dosing, but obtain a higher percentage of drug being delivered based on the percentage of drug released. Specifically, it was determined that the drug should be released within an inspiratory flow rate range of 0.10 to 2.0 liters per second and at an inspiratory volume in the range of about 0.15 to about 0.80 liters. This range is shown by the rectangularly shaped column of figure 11.

In that intrapulmonary drug delivery systems often provide for erratic dosing it is important to provide a method which allows for consistent, repeatable dosing. This is obtained by simultaneously and separately considering both inspiratory flow rate and inspiratory volume in order to determine a point by its abscissa and ordinate. If both measurements are separately considered the drug can be released anywhere along the abscissa and ordinate scales shown in figure 9. Once a point is selected (such as by randomly selecting a point in box A of the graph of figure 9) that selected point (with the same coordinants) is used again and again by a given patient to obtain repeatable dosing. If only one parameter is

- 36 -

measured (abscissa or ordinate) and drug is released based on that parameter the drug release point is defined by a line on the graph of figure 5. When drug is released again the release can be at any point on that line. For example, 5 the inspiratory flow rate (measured horizontally on the abscissa) might be defined by a point. However, the inspiratory volume (which was not measured and/or considered) would be defined only by a vertical line. Thus, subsequent releases would be at different volumes 10 along that vertical line and the dosing would not be consistent. By measuring both inspiratory flow rate on the abscissa and inspiratory volume on the ordinant the coordinants will mark a point for drug release. That point can be found again and again to obtain repeatability in 15 dosing. The same point should be selected each time as closely as possible and within a margin of errors of $\pm 10\%$ with respect to each criteria. The margin for error can be increased and still maintain acceptable levels of repeatable dosing - but the error should keep the drug 20 release point inside the box A of figure 9.

By examining delivery of drug associated with the data points plotted in figure 9, it is possible to determine a preferred and particularly preferred and most preferred range as per figures 11, 12 and 13. The 25 preferred range of figure 11 shows drug released at a volume of 0.15 to 0.8 liters and rate of 0.10 to 2.0 liters/second. The particularly preferred range plotted in figure 12 indicates that the inspiratory flow should be within the range of 0.2 to about 1.8 liters per second with 30 an inspiratory volume in the range of 0.15 to about 0.4 liters. The most preferred range (figure 13) is from about 0.15 to about 1.8 liters per second for the inspiratory flow rate and about 0.15 to about 0.25 liters for the inspiratory volume. Thus, preferred delivery can be 35 obtained by (1) repeatedly delivering aerosolized

- 37 -

formulation to a patient at the same simultaneously and separately measured inspiratory flow rate and inspiratory volume and (2) releasing drug to the patient within specified therapeutically effective ranges as shown within 5 figures 11, 12 and 13. The invention involves releasing drug (after measuring) inside the ranges as per figures 11, 12 or 13. Thus, the release could begin inside or outside the range. Preferably the drug release begins inside the range and more preferable begins and ends inside the ranges 10 of figures 11, 12 or 13.

The methodology of the invention may be carried out using a portable, hand-held, battery-powered device as disclosed herein which uses a microprocessor as per U.S. Patents Nos. 5,404,871, issued April 11, 1995 and 15 5,450,336, issued September 12, 1995 incorporated herein by reference. In accordance with another system the methodology of the invention could be carried out using the device, dosage units and system disclosed in US 94/05825 with modifications as described herein. In 20 accordance with the present system the analgesic drug (which is preferably a narcotic) is included in an aqueous formulation which is aerosolized by moving the formulation through a flexible porous membrane. Alternatively, the methodology of the invention could be carried out using a 25 mechanical (non-electronic) device. Those skilled in the art recognized that various components can be mechanically set to actuate at a given inspiratory flow rate (e.g. a spring biased valve) and at a given volume (e.g. a spinable flywheel which rotates a given amount per a given volume). 30 The components of such devices could be set to allow drug release inside the parameters of figures 11, 12 or 13.

The analgesic drug which is released to the patient may be in a variety of different forms. For example, the drug may be an aqueous solution of drug, i.e., drug 35 dissolved in water and formed into small particles to

- 38 -

create an aerosol which is delivered to the patient. Alternatively, the drug may be in a solution wherein a low-boiling point propellant is used as a solvent. In yet, another embodiment the drug may be in the form of a dry powder which is intermixed with an airflow in order to provide for particlized delivery of drug to the patient. Regardless of the type of drug or the form of the drug formulation, it is preferable to create drug particles having a size in the range of about 0.5 to 5 microns. By creating drug particles which have a relatively narrow range of size, it is possible to further increase the efficiency of the drug delivery system and improve the repeatability of the dosing. Thus, it is preferable that the particles not only have a size in the range of 0.5 to 5 microns but that the mean particle size be within a narrow range so that 80% or more of the particles being delivered to a patient have a particle diameter which is within $\pm 50\%$ of the average particle size, preferably $\pm 20\%$ and more preferably $\pm 5\%$ of the average particle size.

The velocity at which the aerosolized drug is released to the patient is also important in terms of obtaining a high degree of repeatability in dosing and providing for a high percentage of drug being delivered to the patient's lungs. Most preferably, the drug is released from a container in a direction which is normal to the patient's airflow. Accordingly, the drug may be released directly upward so that its flow is at a 90° angle with respect to the patient's inspiratory flow which is preferably directly horizontal. After being released, the drug velocity decreases and the drug particles remain suspended for a sufficient period of time to allow the patient's inspiration to draw the drug into the patient's lungs. The velocity of drug released in the direction from the drug release point to the patient may match the patient's inspiratory flow rate but is preferably slower

W

5

10

15

20

25

30

35

- 40 -

on the density and viscosity of the formulation keeping in mind that the object is to provide aerosolized particles having a diameter in the range of about 0.5 to 5 microns.

The drug formulation may be a low viscosity liquid formulation. The viscosity of the drug by itself or in combination with a carrier is not of particular importance. However, the formulation must have characteristics such that it can be forced out of openings to form an aerosol, e.g., using force (e.g., 20 to 500 psi) to form an aerosol preferably having a particle size in the range of about 0.5 to 5 microns.

Drug may be stored in and/or released from a container of any desired size. In most cases the size of the container is not directly related to the amount of drug being delivered in that most formulations include relatively large amounts of excipient material e.g. water or a saline solution. Accordingly, a given size container could include a wide range of different doses by varying drug concentration.

The amount of analgesic drug delivered to the patient will vary greatly depending on the particular drug being delivered. In accordance with the present invention it is possible to deliver a wide range of analgesic drugs. For example, drugs included within the container could be drugs which have a systemic effect such as narcotic drugs, for example morphine, fentanyl and sufentanil. Other useful drugs include those in a class known as NSAID's or non-steroidal anti-inflammatory drugs - particularly ketorolac and including acetaminophen, and ibuprofen.

Drug containers may include indices which may be electronic and may be connected to a power source such as a battery. When the indices are in the form of visually perceivable numbers, letters or any type of symbol capable of conveying information to the patient. Alternatively, the indices may be connected to a power source such as a

- 41 -

battery when the indices are in the form of magnetically, optically or electronically recorded information which can be read by a drug dispensing device which in turn provides visual or audio information to the user. The indices can
5 be designed for any desired purpose but in general provides specific information relating to the day and/or time which the drug within a container should be administered to the patient. Such indices may record, store and transfer information to a drug dispensing device regarding the
10 number of doses remaining in the container. The containers may include labeling which can be in any format and could include days of the month or other symbols or numbers in any variation or language.

In addition to disclosing specific information
15 regarding the day and time for drug delivery the indices could provide more detailed information such as the amount of drug dispensed from each container which might be particularly useful if the containers included different amounts of drug. Further, magnetic, optical and/or
20 electronic indices could have new information recorded onto them which information could be placed there by the drug dispensing device. For example, a magnetic recording means could receive information from the drug dispensing device indicating the precise time which the drug was actually
25 administered to the patient. In addition to recording the time of delivery the device could monitor the expected efficacy of the delivery based on factors such as the inspiratory flow rate which occurred following the initial release of drug. The information recorded could then be
30 read by a separate device, interpreted by the care-giver and used to determine the usefulness of the present treatment methodology. For example, if the patient did not appear to be responding well but the recorded information indicating that the patient had taken the drug at the wrong
35 time or that the patient had misdelivered drug by changing

- 42 -

inspiratory flow rate after initial release it might be determined that further education in patient use of the device was needed but that the present dosing methodology might well be useful. However, if the recordings indicated
5 that the patient had delivered the drug using the proper techniques and still not obtained the correct results a different drug or dosing methodology might be recommended.

The method of managing a patient's pain may be carried out using a hand-held, portable device comprised of
10 (a) a device for holding a disposable package comprised of at least one but preferably a number of drug containers, (b) a propellant or a mechanical mechanism for moving the contents of a container through a porous membrane (c) a monitor for analyzing the inspiratory flow, rate and volume
15 of a patient, and (d) a switch for automatically releasing or firing the mechanical means after the inspiratory flow and/or volume reaches a threshold level. The device may also include a transport mechanism to move the package from one container to the next. The entire device is self-
20 contained, light weight (less than 1 kg preferably less than 0.5 kg loaded) and portable.

The device may include a mouth piece at the end of the flow path, and the patient inhales from the mouth piece which causes an inspiratory flow to be measured within the
25 flow path which path may be in a non-linear flow-pressure relationship. This inspiratory flow causes an air flow transducer to generate a signal. This signal is conveyed to a microprocessor which is able to convert, continuously, the signal from the transducer in the inspiratory flow path
30 to a flow rate in liters per minute. The microprocessor can further integrate this continuous air flow rate signal into a representation of cumulative inspiratory volume. At an appropriate point in the inspiratory cycle, the microprocessor can send a signal to an actuation means
35 (and/or a vibration device below the resonance cavity).

- 43 -

When the actuation means is signaled, it causes the mechanical means (by pressure or vibration) to move drug from a container on the package into the inspiratory flow path of the device and ultimately into the patient's lungs. After being released, the drug and carrier will pass through a porous membrane which is vibrated to aerosolize the formulation and thereafter the lungs of the patient.

Convex/Flexible Porous Membrane

As shown in Figure 3 the convex shape that the flexible membrane 3 takes on during use plays an important role. The membrane may be rigid and convex such as the rigid convex membrane 80 shown in Figure 8. Alternatively, formulation 5 is forced from the container 1 by force applied from a source such as the piston or plate 24 causing the formulation 5 to press against a flexible membrane 3 causing it to convex outward beyond the plan of the resting surface of the membrane 3 and beyond the plan of the inner surface of the channel 11 which is aligned with the surface of membrane 3 when the container 1 is in a drug release position. The convex shape of the membrane 3 is shown in Figure 3. The convex upward distortion of the membrane is important because it positions the pores of the membrane beyond the boundary layer 13 (shown in Figure 3) into faster moving air of the channel 29. A number of containers may be connected together to form a package 46 as is shown in Figure 7. The package 8 is in the form of an elongated tape but can be in any configuration, e.g., circular, square, rectangular, etc.

When pores of the membrane 3 are positioned beyond the boundary layer into the faster moving air of the channel advantages are obtained. Specifically, the (1) formulation exiting the pores is moved to an air stream where it can be readily carried to the patient and (2) the particles formed do not exit into slow moving or "dead" air

- 44 -

and thus do not rapidly decelerate to a degree such that particles behind them catch up with, collide into and merge with the particle. Particle collisions are not desirable because they (a) result in particles which are too large
5 and cannot be efficiently inhaled into the lung; and (b) result in an aerosol with diverse and unpredictable particle sizes. Either or both (a) and (b) can result in erratic dosing.

The air-heating mechanism 14 heats the surrounding
10 air within the flow path 29. This causes carrier in the formulation to be evaporated more readily. If sufficient heat is added the only material reaching the patient is the substantially dry analgesic drug.

The methodology of the present invention could be
15 carried out with a device that obtains power from a plug-in source. However, the device is preferably a self-contained, hand-held device which is battery powered. Heating mechanisms of various types can be used. For example, see the heating mechanism in the self-contained,
20 portable sealer for plastic colostomy bags in French patent 2,673,142 which is incorporated herein by reference. A portable heater is also taught in European patent applications 0,430,566 A2 for a "Flavor delivering article" and 0,358,002 for "Smoking articles utilizing electric
25 energy," both of which are incorporated herein by reference to disclose and describe heating components powered by batteries.

Recording Information

The device preferably includes a means for recording
30 a characterization of the inspiratory flow profile for the patient which is possible by including a microprocessor in combination with a read/write memory means and a flow measurement transducer. By using such devices, it is possible to change the firing threshold at any time in

- 45 -

response to an analysis of the patient's inspiratory flow profile, and it is also possible to record drug dosing events over time. In a particularly preferred embodiment the characterization of the inspiratory flow can be recorded onto a recording means on the disposable package.

The pre-programmed information is contained within a nonvolatile memory which can be modified via an external device. In another embodiment, this pre-programmed information is contained within a "read only" memory which can be unplugged from the device and replaced with another memory unit containing different programming information. In yet another embodiment, a microprocessor, containing read only memory which in turn contains the pre-programmed information, is plugged into the device. For each of these three embodiments, changing the programming of the memory device readable by a microprocessor will radically change the behavior of the device by causing the microprocessor to be programmed in a different manner. This is done to accommodate different drugs for different types of treatment.

In one embodiment of the methodology of the invention several different criteria are simultaneously considered. (1) The inspiratory flow rate and inspiratory volume are simultaneously and separately measured to insure repeatability. (2) The drug is released inside the parameters of figures 11, 12 or 13 with figure 13 parameters being most preferred. (3) The particle size of the released drug is in the range of 0.5 to 5 microns and 80% or more and the particles have the same size as the average particle size $\pm 10\%$ in size. (4) The drug particles are released at a velocity which is obtained at a flow rate in the range of greater than -2.0 liters/sec. and less than 2.0 liters/sec. As indicated early the actual velocity can vary based on a number of factors. The release velocity should be determined so that the particles

- 46 -

are at or are slowed to zero velocity after traveling about 0.5 to 2 cm from the release point in the absence of patient inhalation. In the presence of inhalation flow the particles move along with the flow - not faster than the flow. The speed being measured from the drug release point in a direction toward the back of the throat of the patient.

After dosing a patient with a systemic analgesic drug it is desirable to take blood samples and make adjustments as needed to obtain the desired drug to blood ratio. In accordance with all methods the patient does not push a button to release drug. The drug is released automatically by signals from the microprocessor using measurements obtained.

The amount of analgesic drug delivered to the patient will vary greatly depending on the particular drug being delivered. In accordance with the present invention it is possible to deliver a wide range of different analgesic and narcotic drugs with the most preferred drug being sufentanil which is generally administered to a patient in an amount in the range of about 2.5 μg - 100 μg . It is pointed out that sufentanil is approximately ten times more potent than fentanyl (another preferred drug) so that fentanyl is generally delivered to a patient in an amount of about 25 μg - 1000 μg . These doses are based on the assumption that when interpulmonary delivery methodology is used the efficiency of the delivery is approximately 10% and adjustments in the amount released must be made in order to take into account the efficiency of the device. The differential between the amount of analgesic drug actually released from the device and the amount of analgesic drug actually delivered to the patient varies due to a number of factors. In general, devices used with the present invention can have an efficiency as low as 10% and as high as 50% or more meaning that as

- 47 -

little as 10% of the released analgesic drug may actually reach the circulatory system of the patient and as much as 50% or more might be delivered. The efficiency of the delivery will vary somewhat from patient to patient and
5 must be taken into account when programming the device for the release of analgesic drug. In general, a conventional metered dose inhaling (MDI) device is about 10% efficient. Devices of the present invention are two to ten times more efficient than conventional MDI devices.

10 When administering analgesic drug, the entire dosing event can involve the administration of anywhere from 1 μ l to 100 ml, but more preferably involves the administration of approximately 10 μ l to 10 ml of formulation. The large variation in the amounts which might be delivered are due
15 to the fact that different drugs have greatly different potencies may be present in the formulation in different concentrations and may be delivered from devices which vary greatly in terms of the efficiency of drug delivered. The entire dosing event may involve several inhalations by the
20 patient with each of the inhalations being provided with one or multiple bursts of analgesic drug from the device.

In addition to drug potency and delivery efficiency, analgesic drug sensitivity must be taken into consideration. The present invention makes it possible to
25 vary dosing over time if analgesic sensitivity changes and/or if user compliance and/or lung efficiency changes over time.

The respiratory rate of a patient can be monitored using any technology known to those skilled in the art.
30 For example, respiratory rate can be measured using a device which encircles the patient's chest and which sends a signal each time the chest expands and/or contracts and the device sends a signal and that signal may be received by a drug dispensing device used in connection with the
35 present invention. Alternatively, the EKG of the patient

- 48 -

can be monitored and determinations can be made based on the EKG as to the patient's respiratory rate. This information can also be sent to the drug dispensing device and adjustments can be made in the amount of drug delivered
5 to the patient based on changes and respiratory rate. Changes in the volume of the patient's thorax and/or EKG are only two of many possible ways to measure respiratory rate and adjust drug delivery based thereon.

Based on the above, it will be understood that the
10 dosing or amount of analgesic drug actually released from the device can be changed based on the most immediately prior monitoring event wherein the inspiratory flow of a patient's inhalation is measured.

Variations in doses are calculated by monitoring the
15 effect of respiratory rate in response to known amounts of analgesic drug released from the device. If the response in decreasing the patient's respiratory rate is greater than with previous readings, then the dosage is decreased or the minimum dosing interval is increased. If the
20 response in decreasing respiratory rate is less than with previous readings, then the dosing amount is increased or the minimum dosing interval is decreased. The increases and decreases are gradual and are preferably based on averages (of 10 or more readings of respiratory rates after
25 10 or more dosing events) and not a single dosing event and monitoring event with respect to respiratory rates. The present invention can record dosing events and respiratory rates over time, calculate averages and deduce preferred changes in administration of analgesic drug.

30 One of the important features and advantages of the present invention is that the microprocessor can be programmed to take two different criteria into consideration with respect to dosing times. Specifically, the microprocessor can be programmed so as to include a

- 49 -

minimum time interval between doses i.e. after a given delivery another dose cannot be delivered until a given period of time has passed. Secondly, the timing of the device can be programmed so that it is not possible to exceed the administration of a set maximum amount of drug within a given time. For example, the device could be programmed to prevent dispersing more than 200 micrograms of a narcotic within one hour. More importantly, the device can be programmed to take both criteria into consideration. Thus, the device can be programmed to include a minimum time interval between doses and a maximum amount of drug to be released within a given time period. For example, the microprocessor could be programmed to allow the release of a maximum of 200 micrograms of a narcotic during an hour which could only be released in amounts of 25 micrograms with each release being separated by a minimum of five minutes.

The dosing program can be designed with some flexibility. For example, if the patient normally requires 25 mg per day of analgesic drug, the microprocessor of the inhalation device can be programmed to prevent further release of the valve after 35 mg have been administered within a given day. Setting a slightly higher limit would allow for the patient to administer additional analgesic drug, if needed, due to a higher degree of pain and/or account for misdelivery of analgesic drug such as due to coughing or sneezing during an attempted delivery.

The ability to prevent overdosing is a characteristic of the device due to the ability of the device to monitor the amount of analgesic drug released and calculate the approximate amount of analgesic drug delivered to the patient based on monitoring given events such as the respiratory rate. The ability of the present device to prevent overdosing is not merely a monitoring system which prevents further manual actuation of a button.

- 50 -

As indicated above, the device used in connection with the present invention is not manually actuated, but is fired in response to an electrical signal received from a microprocessor (which received data from a monitoring
5 device such as a device which monitors inspiratory flow) and allows the actuation of the device upon achieving an optimal point in a inspiratory cycle. When using the present invention, each release of the valve is a release which will administer drug to the patient in that the valve
10 is released in response to patient inhalation. More specifically, the device does not allow for the release of analgesic drug merely by the manual actuation of a button to fire a burst of analgesic drug into the air or a container.

15 The microprocessor will also include a timing device. The timing device can be electrically connected with visual display signals as well as audio alarm signals. Using the timing device, the microprocessor can be programmed so as to allow for a visual or audio signal to
20 be sent when the patient would be normally expected to administer analgesic drug. In addition to indicating the time of administration (preferably by audio signal), the device can indicate the amount of analgesic drug which should be administered by providing a visual display. For
25 example, the audio alarm could sound alerting the patient that analgesic drug should be administered. At the same time, the visual display could indicate "50 μg " as the amount of analgesic drug to be administered. At this point, a monitoring event could take place. After
30 completion of the monitoring event, administration would proceed and the visual display would continually indicate the remaining amount of analgesic drug which should be administered. After the predetermined dose of 50 μg had been administered, the visual display would indicate that
35 the dosing event had ended. If the patient did not

- 51 -

complete the dosing event by administering the stated amount of analgesic drug, the patient would be reminded of such by the initiation of another audio signal, followed by a visual display instructing the patient to continue
5 administration. This process can be readily repeated when the inspiratory flow profile is changed for whatever reason, e.g., abdominal incisional pain resulting in low tidal volumes. Determination of optimal drug delivery points in the inspiratory flow can be done at each dosing
10 event, daily, weekly, or with the replacement of a new package or container in the device.

Additional information regarding dosing with analgesic drug via injection can be found within Anesthesia, (most recent edition) edited by Miller, and published by
15 Churchill and Livingston and Harrison's - Principles of Internal Medicine (most recent edition) published by McGraw Hill Book Company, New York, incorporated herein by reference to disclose conventional information regarding dosing analgesic drug via injection.

20 Supplemental Treatment Methodology

Patients suffering from pain may be treated solely with analgesic drug as indicated above, i.e. by intrapulmonary delivery. However, it is possible to treat such patients with a combination of analgesic drug(s)
25 provided by other means of administration. More specifically, a patient can be provided with a basal level of analgesic drug by a means such as transdermal administration and/or oral administration. This basal level of drug will be sufficient to control the pain of the
30 patient during normal circumstances. However, when the pain becomes more intense, the patient can quickly obtain relief by the intrapulmonary administration of an analgesic drug such as sufentanil using the device and methodology of the present invention. The intrapulmonary delivery of

- 52 -

analgesic drug provides a pulsatile rate increase over the normal basal rate level maintained by the oral or transdermal administration. The use of the intrapulmonary administration of analgesic drug via the present invention
5 is particularly desirable in that the effects of the drug are felt almost immediately. Such an immediate effect cannot be obtained using oral and/or transdermal administration means.

Fentanyl is available for administration by a
10 transdermal delivery system in the form of a skin patch [Duragesic™ (fentanyl transdermal system) package insert, Janssen Pharmaceutica, Piscataway, NJ 08855, Jan-Jun 1991].

In addition to administering narcotics by transdermal administration it is possible to administer the
15 drugs by other means such as by injection and/or orally. In accordance with the present invention a preferred supplemental means of administration is oral in that oral administration can be carried out on an out-patient basis. Thus, the method of the invention may be carried out by
20 administering a long acting orally effective narcotic drug. The oral drug is preferably given in amount so as to maintain a relatively low level of narcotic within the circulatory system which is sufficient to control pain during periods when the pain is less severe. However, this
25 low level of drug to blood ratio must be raised in order to control more severe pain and such can be accomplished by the intrapulmonary administration of narcotic using the present invention.

Based on the above, it will be understood by those
30 skilled in the art that a plurality of different treatments and means of administration can be used to treat a single patient. For example, a patient can be simultaneously treated with analgesic drug by injection, analgesic drug via intrapulmonary administration in accordance with the
35 present invention, and drugs, which are orally

- 53 -

administered. Should such prove to be ineffective for whatever reason, such as breathing difficulties (not related to the administration of the analgesic drug), such could be supplemented by administration via injection.

5 Treating Overdoses with Narcotic Antagonist

The methodologies of the present invention can be carried out using any type of analgesic drug, although they are preferably carried out using potent narcotic such as fentanyl and morphine. The biochemical mechanism of action
10 of such narcotics is known. Further, it is known that the narcotic effect can be blocked by the administration of a narcotic antagonist such as naloxone. The devices and methodology disclosed and described herein may be used to deliver narcotic antagonists such as naloxone.

15 Drug Delivery Device

The device preferably includes a means for recording a characterization of the inspiratory flow profile for the patient which is possible by including a microprocessor 26
20 in combination with a read/write memory means and a flow measurement transducer. By using such devices, it is possible to change the firing threshold at any time in response to an analysis of the patient's inspiratory flow profile, and it is also possible to record drug dosing events over time. In a particularly preferred embodiment
25 the characterization of the inspiratory flow can be recorded onto a recording means on the disposable package.

Figure 4 shows a cross-sectional plan view of a hand held, self-contained, portable, breath-actuated inhaler device 40 of the present invention. The device 40 is shown
30 with a holder 20 having cylindrical side walls and a hand grip 21. The holder 20 is "loaded" in that it includes a container 1. A plurality of containers 1 (2 or more) are preferably linked together to form a package 46.

- 54 -

The embodiment shown in Figure 4 is a simple version of the invention. The device 40 may be manually actuated and loaded. More specifically, the spring 22 may be compressed by the user until it is forced down below the 5 actuation mechanism 23. When the user pushes the actuation mechanism 23 the spring 22 is released and the mechanical means in the form of a plate 24 is forced upward against a wall 2 of a container 1. When the container 1 is compressed its contents are forced out through the membrane 10 3 and aerosolized. Two additional containers 1 shown to the left is unused. The device of Figure 4 would not require the use of low boiling point propellants such as low boiling point fluorocarbons. Numerous additional features and advantages of the present invention can be 15 obtained by utilizing the monitoring and electronic components described below.

It is important to note that a variety of devices can be used in order to carry out the methodology of the present invention. However, the device must be capable of 20 aerosolizing drug formulation in a container and preferably does such forcing formulation through a porous membrane with the release point based on pre-programmed criteria which may be mechanically set or electronically set via criteria readable by the microprocessor 26. The details of 25 the microprocessor 26 and the details of other drug delivery devices which include a microprocessor and pressure transducer of the type used in connection with the present invention are described and disclosed within U.S. Patent 5,404,871, issued April 11, 1995, entitled "Delivery 30 of Aerosol Medications for Inspiration" which patent is incorporated in its entirety herein by reference, and it is specifically incorporated in order to describe and disclose the microprocessor and program technology used therewith. The use of such a microprocessor with a drug delivery 35 device is disclosed in our earlier filed U.S. Application

- 55 -

Serial No. 08/065,660 filed May 21, 1993 incorporated herein by reference. The pre-programmed information is contained within a nonvolatile memory which can be modified via an external device. In another embodiment, this pre-programmed information is contained within a "read only" memory which can be unplugged from the device and replaced with another memory unit containing different programming information. In yet another embodiment, microprocessor 26, containing read only memory which in turn contains the pre-programmed information, is plugged into the device. For each of these three embodiments, changing the programming of the memory device readable by microprocessor 26 will radically change the behavior of the device by causing microprocessor 26 to be programmed in a different manner. This is done to accommodate different drugs for different types of treatment.

Microprocessor 26 sends signals via electrical connection 27 to electrical actuation device 28 which actuates the means 23 which fires the mechanical plate 24 forcing drug formulation in a container 1 to be aerosolized so that an amount of aerosolized drug is delivered into the inspiratory flow path 29 when the flexible membrane 3 protrudes outward through the flow boundary layer. A signal is also sent to the heater 14 to add heat energy to the air in the flow path 29. The device 28 can be a solenoid, motor, or any device for converting electrical to mechanical energy. Further, microprocessor 26 keeps a record of all drug dosing times and amounts using a read/write non-volatile memory which is in turn readable by an external device. Alternatively, the device records the information onto an electronic or magnetic strip on the package 1. The recorded information can be read later by the care-giver to determine the effectiveness of the treatment. In order to allow for ease of use, it is

- 56 -

possible to surround the inspiratory flow path 29 with a mouth piece 30.

The electrical actuation means 28 is in electrical connection with the flow sensor 31 which is capable of measuring a flow rate of about 0 to about 800 liters per minute. It should be noted that inhalation flow rates are less than exhalation rates, e.g. max for inhalation 200 lpm and 800 lpm for exhalation. A variety of different types of flow sensors may be used as per U.S. Patent 5,394,866, issued March 7, 1995, U.S. Patent 5,404,871, issued April 11, 1995 and U.S. Patent 5,450,336, issued September 12, 1995, which are incorporated herein by reference. The flow sensor 31 includes screens 32, 33 and 34 which are positioned approximately $\frac{1}{4}$ " apart from each other but may be comprised of a single screen or include a non-linear flow path. It is preferable to include the desiccator 41 at a point prior to the screens 32, 33 and 34 in the flow path so that the elimination of water vapor is considered in any measurement.

Tubes 35 and 36 open to the area between the screens 32, 33 and 34 with the tubes 35 and 36 being connected to a conventional differential pressure transducer 37. Another transducer designed to measure outflow through the opening 38 is also preferably included or the flow sensor 31 is designed so that the same components can measure inflow and outflow. When the user draws air through inspiratory flow path 29, air is passed through the screens 32, 33 and 34 and the air flow can be measured by the differential air pressure transducer 37. Alternatively, other means to measure pressure differential related to air flow, such as a conventional measuring device in the air way, may be used. The flow sensor 31 is in connection with the electrical actuation means 28 (via the connector 39 to the processor 26), and when a threshold value of air flow is reached (as determined by the

- 57 -

processor 26), the electrical actuation means 28 fires the release of a mechanical means 23 releasing the plate 24 which forces the release of formulation from a container 1 so that a controlled amount of analgesic is delivered to the patient. The microprocessor 26 is optionally connected to an optionally present vibrating device 45 which may be activated.

Vibration Device

The vibration device 45 creates ultrasonic vibrations which are preferably at right angles to the plane of the membrane 3. The device 45 may be in the form of a piezoelectric ceramic crystal or other suitable vibration mechanism. A vibrating device 45 in the form of a piezoelectric crystal may be connected to the porous membrane by means of an attenuator horn or acoustic conduction mechanism, which when correctly matched with the piezoelectric crystal frequency, efficiently transmits ultrasonic oscillations of the piezoelectric crystal to the resonance cavity and the porous polycarbonate membrane and if sized correctly permits the ultrasonic energy to be focused in a polycarbonate membrane 3 allowing for maximum use of the energy towards aerosolizing the liquid formulation 5. The size and shape of the attenuator horn is not of particular importance. It is preferred to maintain a relatively small size in that the device is hand held. The components are chosen based on the particular material used as the porous material, the particular formulation used and with consideration of the velocity of ultrasonic waves through the membrane to achieve a harmonic relationship at the frequency being used.

A high frequency signal generator drives the piezoelectric crystal. This generator is capable of producing a signal having a frequency of from about 575 kilohertz (Khz) to about 32,000 kilohertz, preferably 1,000

- 58 -

to 17,000 kilohertz, more preferably 2,000 to 4,000 kilohertz. The power output required depends upon the amount of liquid being nebulized per unit of time and the area and porosity of the membrane (generally comprised of a polymeric plastic-like material) used for producing the drug dosage unit and/or the efficiency of the connection.

Vibration is applied while the formulation is being forced from the pores of the polycarbonate membrane. The formulation can be aerosolized with only vibration i.e., without applying pressure. Alternatively, when vibration is applied in certain conditions the pressure required for forcing the liquid out can be varied depending on the liquid, the size of the pores and the shape of the pores but is generally in the range of about 50 to 600 psi, preferably 100 to 500 psi and may be achieved by using a piston, roller, bellows, a blast of forced compressed gas, or other suitable device. The vibration frequency used and the pressure applied can be varied depending on the viscosity of the liquid being forced out and the diameter and length of the openings or pores.

It is desirable to force formulation through the porous membrane with a relatively low pressure e.g., pressure less than 500 psi in that lower pressure reduces the chance of breaking the membrane during the release of formulation and makes it possible to make a thinner membrane. The thinner membranes make it easier to make small holes in that the holes or pores of the membrane are created using a focussed LASER. It is possible to reduce the pressure further by making the holes conical in cross-section. A LASER with a conical focus is used to burn holes through the membrane. The larger diameter of the conical shape is positioned next to the formulation and the smaller diameter opening is the opening through which the formulation ultimately flows. The ratio of the smaller opening to the diameter of the larger opening is in the

- 59 -

range of about 1:2 to about 1:20 i.e., the larger opening is between 2 and 20 times the diameter of the smaller opening. By creating conical openings wherein the smaller end of the cone has a diameter of less than 6 microns it is possible to produce particles which have a diameter of less than 12 microns and it is also possible to force the formulation through the pores using a pressure of less than 500 psi. The small end of the conical opening preferably has a diameter of less than 3 microns for systemic delivery and less than 5 microns for pulmonary delivery and the pressure used for forcing formulation through the pores is preferable less than 350 psi.

When small aerosolized particles are forced into the air, the particles encounter substantial frictional resistance. This may cause particles to slow down more quickly than desired and may result in particles colliding into each other and combining, which is undesirable with respect to maintaining the preferred particle size distribution within the aerosol. In order to aid in avoiding the particle collision problem, it is possible to include a means by which air flow and the flexible membrane prevent collisions. Specifically, the patient inhales thereby creating an air flow toward the patient over the protruding membrane 3. The air flow carries the formed particles along and aids in preventing their collision with each other. The shape of the container opening, the shape of the membrane covering that opening, as well as the positioning and angling of the flow of air through the channel 11 relative to the direction of formulation exiting the pores of the membrane 3 can be designed to aid in preventing particle collision. It is desirable to shape the opening and matching membrane so as to minimize the distance between any edge of the opening and the center of the opening. Accordingly, it is not desirable to form a circular opening which would maximize the distance between

- 60 -

the outer edges of the circle and the center of the circle, whereas it is desirable to form an elongated narrow rectangular opening covered by a rigid membrane 80 as shown in Figure 8. Using such a configuration makes it possible
5 to better utilize the air flow relative to all of the particles of formulation being forced from the pores of the membrane 3. When a circular opening is used, particles which are towards the center of the circle may not be carried along by the air being drawn over the membrane 3
10 and will collide with each other. The elongated rectangle could be formed in a circle, thereby providing an annular opening and air could be forced outward from the outer and inner edges of the circle formed. Further details regarding such are described in U.S. patent application
15 Serial No. 08/247,012, filed May 20, 1994 which is incorporated herein by reference to disclose and describe such.

Operation of the Device 40

The device of Figure 4 shows all of the components
20 present within the single, hand-held, portable breath actuated device, e.g. the microprocessor 26 and flow sensor 31 used to provide the electronic breath actuated release of drug. The device of Figure 4 includes a holding means and mechanical means and preferably operates
25 electronically, i.e. the actuation means is preferably not directly released by the user. The patient inhales through inspiratory flow path 29 which can form a mouth piece 30. Air enters the device via the opening 38. The inhaling is carried out in order to obtain a metering event using the
30 differential pressure transducer 37. Further, when the inspiratory flow meets a threshold of a pre-programmed criteria, the microprocessor 26 sends a signal to an actuator release electrical mechanism 28 which actuates the mechanical means 23, thereby releasing a spring 22 and

- 61 -

plate 24 or equivalent thereof, forcing aerosolized formulation into the channel 11, and out of the membrane 3 into the flow path 29 where the air surrounding the particles is optionally heated by the air heater 14.

5 Further details regarding microprocessors 26 of Figure 4 are described within U.S. Patent 5,394,866, issued March 7, 1995, entitled "An Automatic Aerosol Medication Delivery System and Methods", which is incorporated herein by reference in its entirety and specifically incorporated in

10 order to describe and disclose flow measurements, the microprocessor and program technology used therewith.

Microprocessor 26 of Figure 4 includes an external non-volatile read/write memory subsystem, peripheral devices to support this memory system, reset circuit, a

15 clock oscillator, a data acquisition subsystem and a visual annunciator subsystem. The discrete components are conventional parts which have input and output pins configured in a conventional manner with the connections being made in accordance with instructions provided by the

20 device manufacturers. The microprocessor used in connection with the device of the invention is designed and programmed specifically so as to provide controlled and repeatable amounts of analgesic to a patient upon actuation. The microprocessor must have sufficient

25 capacity to make calculations in real time. Adjustments can be made in the program so that when the patient's inspiratory flow profile is changed such is taken into consideration. This can be done by allowing the patient to inhale through the device as a test (monitoring event) in

30 order to measure air flow with preferred drug delivery points determined based on the results of several inhalations by each particular patient. This process can be readily repeated when the inspiratory flow profile is changed for whatever reason. When the patient's lung

35 function has decreased the program will automatically back

- 62 -

down in terms of the threshold levels required for release of drug. This "back down" function insures drug delivery to a patient in need but with impaired lung function. Determination of optimal drug delivery points in the inspiratory flow can be done at each dosing event, daily, weekly, or with the replacement of a new cellular array in the device.

The microprocessor 26 of the present invention, along with its associated peripheral devices, can be programmed so as to prevent triggering the actuation mechanism 28 more than a given number of times within a given period of time. This feature makes it possible to prevent overdosing the patient. The overdose prevention feature can be particularly designed with each individual patient in mind or designed with particular groups of patients in mind. For example, the microprocessor can be programmed so as to prevent the release of more than approximately 30 mg of analgesic per day when the patient is normally dosed with approximately 25 mg of analgesic drug per day. The device can be designed to switch off this lock-out function so that analgesic can be delivered in an emergency situation.

The systems can also be designed so that only a given amount of analgesic drug is provided at a given dosing event. For example, the system can be designed so that only approximately 10 μ g of analgesic drug is given in a given 15-minute period over which the patient will make approximately 10 inhalations with 1 μ g of drug being delivered with each inhalation. By providing this feature, greater assurances are obtained with respect to delivering the analgesic drug gradually over time and thereby managing pain without overdosing the patient.

The microprocessor 26 of the invention can be connected to external devices permitting external information to be transferred into the microprocessor of

- 63 -

the invention and stored within the non-volatile read/write memory available to the microprocessor. The microprocessor of the invention can then change its drug delivery behavior based on this information transferred from external
5 devices. All of the features of the invention are provided in a portable, programmable, battery-powered, hand-held device for patient use which has a size which compares favorably with existing metered dose inhaler devices.

The microprocessor 26 of the present invention is
10 programmed so as to allow for monitoring and recording data from the inspiratory flow monitor without delivering drug. This is done in order to characterize the patient's inspiratory flow profile in a given number of monitoring events, which monitoring events preferably occur prior to
15 dosing events. After carrying out a monitoring event, the preferred point within the inspiratory cycle for drug delivery can be calculated. This calculated point is a function of measured inspiratory flow rate as well as calculated cumulative inspiratory flow volume. This
20 information is stored and used to allow activation of the electronic actuation means when the inhalation cycle is repeated during the dosing event.

The microprocessor of the present invention, along with its associated peripheral devices, can be programmed
25 so as to prevent the release of drug from the canister from occurring more than a given number of times within a given period of time. This feature makes it possible to prevent overdosing the patient with a potent narcotic. The overdose prevention feature can be particularly designed
30 with each individual patient in mind or designed with particular groups of patients in mind. For example, the microprocessor can be programmed so as to prevent the release of more than approximately 200 μg of fentanyl per day when the patient is normally dosed with approximately
35 100 μg of fentanyl per day. The systems can also be

- 64 -

designed so that only a given amount of a particular analgesic drug is provided at a given dosing event. For example, the system can be designed so that only approximately 100 μg of fentanyl is given in a given
5 15-minute period over which the patient will make approximately 10 inhalations with 10 μg of fentanyl being delivered with each inhalation. By providing this feature, greater assurances are obtained with respect to delivering the analgesic drug gradually over time and thereby
10 providing pain management without overdosing the patient.

Another feature of the device is that it may be programmed to not release drug if it does not receive a signal transmitted to it by a transmitter worn by the intended user. Such a system improves the security of the
15 device and prevents abuse by unauthorized users.

The microprocessor of the invention can be connected to external devices permitting external information to be transferred into the microprocessor of the invention and stored within the non-volatile read/write memory available
20 to the microprocessor. The microprocessor of the invention can then change its drug delivery behavior based on this information transferred from external devices. All of the features of the invention are provided in a portable, programmable, battery-powered, hand-held device for patient
25 use which has a size which compares favorably with existing metered dose inhaler devices.

Method of Administration

The method and device of the invention provides a number of features which make it possible to achieve the
30 controlled and repeatable dosing procedure required for the managing pain with potent analgesic drugs with a low therapeutic index. First, the membrane is permanently convex or is flexible and protrudes into fast moving air aiding the elimination of particle collisions. Second, the

- 65 -

invention makes it possible to eliminate any carrier from the aerosolized particles and provide substantial dry analgesic particles to a patient which particles can be manufactured to have a uniform size. By delivering
5 particles of uniform size repeatability of dosing is enhanced regardless of the surrounding environment, e.g. different humidity conditions. Third, the device makes it possible to administer drug at the same point with respect to inspiratory flow rate and inspiratory volume at each
10 drug delivery point thereby improving repeatability of dosing.

The method of the invention involves the release of a liquid, flowable analgesic formulation from individual disposable containers which may be interconnected in a
15 package. This is desirable in that the liquid, flowable drug is packaged under a sterile environment and therefore does not require and preferably does not include additional materials such as antifungal, bacteriostatics, and preservatives which would normally be required in a liquid
20 formulation if the formulation was to be opened, exposed to air, closed and later used again. A new container and membrane are used for each release of drug. Thus, the membrane and container are disposable thereby preventing clogging of pores which takes place with reuse. The
25 invention does not require the use of low boiling point propellants such as low boiling point fluorocarbons. The use of such low boiling point propellants in conventional metered dose inhaler devices is desirable because such propellants eliminate the need for preservatives,
30 antifungal and bacteriostatic compounds. However, there are potential environmental risks to using low boiling point fluorocarbons. Accordingly, the present invention provides potential environmental benefits and would be particularly useful if government regulations prevented

- 66 -

further use of devices which dispensed low boiling point fluorocarbons.

In addition to environmental advantages, the present invention offers advantages due to the relatively slow
5 speed at which the aerosol dispersion is delivered to the patient. A conventional metered dose inhaler device discharges the aerosol outward at a relatively high rate of speed which causes a large amount of the aerosol particles to make contact with the inside of the patient's mouth and
10 the back of the patient's throat. This decreases the amount of drug actually administered to the patient's lungs as compared with the present system, wherein the aerosol is delivered at a relatively slow rate of speed and can be inhaled slowly by the patient.

15 The method preferably uses a drug delivery device which is not directly actuated by the patient in the sense that no button is pushed nor valve released by the patient applying physical pressure. On the contrary, the device of the invention provides that the actuation mechanism which
20 causes drug to be forced from a container is fired automatically upon receipt of a signal from a microprocessor programmed to send a signal based upon data received from a monitoring device such as an airflow rate monitoring device. A patient using the device withdraws
25 air from a mouthpiece and the inspiratory rate, and calculated inspiratory volume of the patient is measured simultaneously one or more times in a monitoring event which determines an optimal point in an inhalation cycle for the release of a dose of any desired drug. Inspiratory
30 flow is preferably measured and recorded in one or more monitoring events for a given patient in order to develop an inspiratory flow profile for the patient. Recorded information is preferably analyzed by the microprocessor in order to deduce a preferred point within the patient's
35 inspiratory cycle for the release of drug with the

- 67 -

preferred point being calculated based on the most likely point to result in a reproducible delivery event.

A flow rate monitoring device continually sends information to the microprocessor, and when the
5 microprocessor determines that the optimal point in the respiratory cycle is reached, the microprocessor actuates a component which fires a mechanical means (and activates the vibration device) which causes drug to be forced out of the container and aerosolized. Accordingly, drug is
10 repeatedly delivered at a pre-programmed place in the inspiratory flow profile of the particular patient which is selected specifically to maximize reproducibility of drug delivery and peripheral deposition of the drug. It is pointed out that the device of the present invention can be
15 used to, and actually does, improve the efficiency of drug delivery. However, this is not the most important feature. A more important feature is the reproducibility of the release of a tightly controlled amount of drug (with a narrow range of particle size) repeatedly at the same
20 particular point in the respiratory cycle so as to assure the delivery of a controlled and repeatable amount of drug to the lungs of each individual patient, i.e. intrapulmonary drug delivery with tightly controlled dosing. The heating component(s) and/or the desiccator to
25 remove water vapors aid in providing repeatability in dosing in that the particles reaching the patient will have the same size regardless of the surrounding humidity. By keeping the particle size the same at each dosing event the particles deposit at the same general area of the lung at
30 each event. These features improve repeatability along with automatic control of the drug release mechanism, combined with frequent monitoring events in order to calculate the optimal flow rate and time for the release of drug. Further, the particles will have uniform size in that
35 all carrier is removed regardless of the humidity of the

- 68 -

surrounding environment. Because the drug release mechanism is fired automatically and not manually, it can be predictably and repeatedly fired at that same point in the inspiratory cycle. Because dosing events are
5 preferably preceded by monitoring events, the point in the inspiratory cycle of the release can be readjusted based on the particular condition of the patient. For example, patients suffering from asthma have a certain degree of pulmonary insufficiency which may well change with the
10 administration of drug. These changes will be taken into account in the monitoring event by the microprocessor which will readjust the point of release of the drug in a manner calculated to provide for the administration of an amount of analgesic to the patient presently needed by the patient
15 at each dosing event.

When administering drug using the inhalation device of the present invention, the entire dosing event can involve the administration of anywhere from 10 μ l to 1,000 ml of drug formulation, but more preferably involves
20 the administration of approximately 50 μ l to 10,000 μ l of drug formulation. Very small amounts of drug (e.g., nanogram amounts) may be dissolved or dispersed within a pharmaceutically acceptable, liquid, excipient material to provide a liquid, flowable formulation which can be readily
25 aerosolized. The container will include the formulation having drug therein in an amount of about 10 ng to 300 μ g, more preferably about 50 μ g. The large variation in the amounts which might be delivered are due to different drug potencies and different delivery efficiencies for different
30 devices, formulations and patients. The entire dosing event may involve several inhalations by the patient with each of the inhalations being provided with drug from the device. For example, the device can be programmed so as to release the contents of a single container or to move from
35 one container to the next on a package of interconnected

- 69 -

containers. Delivering smaller amounts from several containers can have advantages. Since only small amounts are delivered from each container and with each inhalation, even a complete failure to deliver drug with a given
5 inhalation is not of great significance and will not seriously disturb the reproducibility of the dosing event. Further, since relatively small amounts are delivered with each inhalation, the patient can safely administer a few additional mg of analgesic without fear of overdosing.

10 In addition to drug potency and delivery efficiency, drug sensitivity must be taken into consideration. The present invention makes it possible to vary dosing over time if sensitivity changes and/or if user compliance and/or lung efficiency changes over time.

15 Based on the above, it will be understood that the dosing or amount of analgesic actually released from the device can be changed based on the most immediately prior monitoring event wherein the inspiratory flow of a patient's inhalation is measured.

20 Variations in doses are calculated by monitoring the effect of one or more lung function parameters in response to known amounts of respiratory drug released from each container and delivered to the patient. If the response in changing measured lung function parameters is greater than
25 with previous readings, then the dosage (number of containers released) is decreased or the minimum dosing interval is increased. If the response in changing measured lung function parameters is less than with previous readings, then the dosing amount is increased or
30 the minimum dosing interval is decreased. The increases and decreases are gradual and are preferably based on averages (of 10 or more readings of lung function parameter after 10 or more dosing events) and not a single dosing event and monitoring event. The preferred drug delivery
35 device of the present invention can record dosing events

- 70 -

and lung function parameters over time, calculate averages and deduce preferred changes in administration of analgesic.

One of the important features and advantages of the present invention is that the microprocessor can be programmed to take a number of different criteria into consideration with respect to dosing times. For example, the microprocessor can be programmed so as to include a minimum time interval between doses i.e. after a given delivery another dose cannot be delivered until a given period of time has passed. Secondly, the timing of the device can be programmed so that it is not possible to exceed the administration of a set maximum amount of drug within a given time. For example, the device could be programmed to prevent dispersing more than ten mg of analgesic within one hour. More importantly, the device can be programmed to take both criteria into consideration. Thus, the device can be programmed to include a minimum time interval between doses and a maximum amount of drug to be released within a given time period. For example, the microprocessor could be programmed to allow the release of a maximum of ten mg of analgesic during an hour which could only be released in amounts of one mg with each release being separated by a minimum of five minutes.

The dosing program can be designed with some flexibility. For example, if the patient normally requires 25 mg per day of analgesic, the microprocessor can be programmed to provide a warning after 25 mg have been administered within a given day and to continue the warning thereafter to alert the user of possible overdoses. By providing a warning and not a lock-out, the device allows for the patient to administer additional analgesic, if needed, due to a decreased lung function, abdominal pain, account for misdelivery of analgesic such as due to coughing or sneezing during an attempted delivery.

- 71 -

The ability to prevent overdosing is a characteristic of the device due to the ability of the device to monitor the amount of analgesic released and calculate the approximate amount of analgesic delivered to
5 the patient based on monitoring a variety of lung function parameters. The ability of the present device to prevent overdosing is not merely a monitoring system which prevents further manual actuation of a button. As indicated above, the device used in connection with the present invention is
10 not manually actuated, but is fired in response to an electrical signal received from a microprocessor (which received data from a monitoring device such as a device which monitors inspiratory flow) and allows the actuation of the device upon achieving an optimal point in a
15 inspiratory cycle. When using the present invention, each actuation of the device will administer drug to the patient in that the device is fired in response to patient inhalation. More specifically, the preferred embodiment of the device does not allow for the release of analgesic
20 merely by the manual actuation of a button to fire a burst of analgesic into the air or a container.

A variety of different embodiments of the dispersion device of the invention are contemplated. In accordance with one embodiment it is necessary to carry out manual
25 cocking of the device. This means that energy is stored such as by retracting a spring so that, for example, a piston can be positioned below the drug containing container. In a similar manner a piston connected to a spring can be withdrawn so that when it is released it will
30 force air through the air dispersion vents. Automatic cocking of forced storing systems for both the drug formulation and the air flow may be separate or in one unit. Further, one may be manual whereas the other may be done automatically. In accordance with one embodiment the
35 device is cocked manually but fired automatically and

- 72 -

electronically based on monitoring the patients inspiratory flow. The formulation may be physically moved through the porous membrane in a variety of different ways. Formulation may be forced through the membrane by a piston
5 or, without applying force to the formulation, the membrane being vibrated at frequencies sufficient to create an aerosol.

The microprocessor 26 of the present invention preferably includes a timing device. The timing device can
10 be electrically connected with visual display signals as well as audio alarm signals. Using the timing device, the microprocessor can be programmed so as to allow for a visual or audio signal to be sent when the patient would be normally expected to administer analgesic. In addition to
15 indicating the time of administration (preferably by audio signal), the device can indicate the amount of analgesic which should be administered by providing a visual display. For example, the audio alarm could sound alerting the patient that analgesic should be administered. At the same
20 time, the visual display could indicate "one dosage unit" as the amount of drug (number of containers) to be administered. At this point, a monitoring event could take place. After completion of the monitoring event, administration would proceed and the visual display would
25 continually indicate the remaining amount of analgesic which should be administered. After the predetermined dose (indicated number of containers) had been administered, the visual display would indicate that the dosing event had ended. If the patient did not complete the dosing event by
30 administering the stated amount of drug, the patient would be reminded of such by the initiation of another audio signal, followed by a visual display instructing the patient to continue administration.

Additional information regarding dosing analgesic
35 can be found within Harrison's - Principles of Internal

- 73 -

Medicine (most recent edition) and the Drug Evaluation Manual, 1993 (AMA-Division of Drugs and Toxicology), both of which are published by McGraw Hill Book Company, New York, incorporated herein by reference to disclose
5 conventional information regarding dosing of analgesic.

Operation of Delivery Device

The device 40 schematically shown within Figure 4 can be specifically operated as follows. A container 1 is loaded into the device 6. The device is then armed meaning
10 that the piston such as the spring-loaded piston 24 is cocked. If applicable another piston (not shown) used to compress the liquid formulation in a dual container system is cocked. Further, a container 1 of the package is moved
15 into position and any cover is stripped off of the porous membrane 3. Thereafter, the patient withdraws air from the mouthpiece 30 and the patient's inhalation profile is developed using the microprocessor 26. After the inhalation profile is determined, the microprocessor calculates a point within the inhalation profile at which
20 the drug should be released in order to maximize repeatability of the dosing, e.g. by plotting a curve of breath velocity versus time and determining the point on the curve most likely to provide repeatability of dosing. However, in order to carry out methodology in accordance
25 with the present invention it is not necessary to plot any curve of breath velocity versus time. The device can be set so that the dose will be repeatedly released at approximately the same point with respect to inspiratory flow rate and inspiratory volume. If the device repeatedly
30 fires at the same inspiratory flow rate and inspiratory volume each time the patient will receive substantially the same dose. Both criteria must be measured and used for firing to obtain repeatability.

- 74 -

Further details with respect to obtaining improved repeatability of dosing in addition to improved delivery efficiency are disclosed within related application entitled: "Intrapulmonary Drug Delivery Within
5 Therapeutically Relevant Inspiratory Flow/Volume Values" filed on July 11, 1994, U.S. Serial No. 08/273,375 which application is incorporated herein by reference. The microprocessor of the present invention can be programmed to release drug based on all or any of the following
10 parameters.

(1) Delivery should be at an inspiratory flow rate inside a range of about 0.10 to about 2.0 liters per second (efficiency can be obtained by delivering at a flow rate in a range of 0.2 to about 1.8 liters per second and more
15 preferably 0.15 to 1.7 liters per second). Repeatability of the delivery is obtained by releasing at substantially the same inspiratory flow rate at each drug release.

(2) Delivery should be at a point within a patient's inspiratory volume of about 0.15 to about 2.0
20 liters (further efficiency of delivery can be obtained by delivering within a range of 0.15 to 0.8 liters and more preferably 0.15 to about 0.4 liters). Repeatability of delivery is obtained by delivering at the same inspiratory volume at each release of drug.

(3) Delivery is improved by providing a system
25 which creates particles for systemic delivery wherein the particles are in the range of about 0.5 to about 12.0 microns, preferably 0.5 to 6 microns and more preferably 0.5 to about 3 microns.

(4) It is desirable to have obtained a
30 concentration of the drug in the carrier in the range of from about 0.01 to about 12.5% preferably 0.1 to 10%. By maintaining the concentration of drug to carrier in this

- 75 -

range it is possible to create particles which are somewhat larger than would be desirable for delivery but to reduce those particles in size by evaporation of carrier.

(5) Air drawn into the flow path of the aerosolized particles is heated by adding energy to each 10 μ l of formulation in an amount of about 20 Joules to 100 Joules, more preferably 20 Joules to 50 Joules. The heated air aids in reducing the effect of humidity and evaporates carrier away from the particles thereby providing smaller particles for inhalation.

(6) Air is added to the aerosolized formulation by the patient drawing air into the aerosolized mist in an amount of about 100 milliliters to 2 liters per 10 microliters of aerosol formulation.

(7) Vibration may be created on the porous membrane in an amount 575 to 32,000, preferably 1,000 to 17,000 and more preferably 2,000 to 4,000 kilohertz.

(8) The pore size of the membrane is regulated within a range of 0.25 to about 6.0 microns, preferably 0.5 to 3 microns and more preferably 1 to 2 microns. This size refers to the diameter of the pore through which the formulation exits the membrane. The diameter of the opening into which the formulation flows may be 2 to 20 times that size in diameter thereby providing a conical configuration.

(9) The viscosity of the formulation affects the amount of pressure which needs to be applied to force the formulation through the pores and should be within the range of 25% to 1,000% the viscosity of water.

(10) The extrusion pressure is regulated within a range of 50 to 600 psi more preferably 100 to 500 psi. Lower pressures may be obtained by using the conical configuration for the pore size.

(11) The microprocessor should also be provided information regarding the ambient temperature and

- 76 -

atmospheric pressure. The temperature is preferably close to room temperature i.e., within a range of 15°C to 30°C. An atmospheric pressure is generally 1 atmosphere or slightly lower at higher altitudes, e.g., about 75% of 1
5 atmosphere.

(12) To provide for consistency in dosing the ratio of the carrier to drug should be maintained constant and more highly soluble drugs are more desirable. However, it is possible to use drugs that are insoluble by creating
10 suspensions or by using solubility enhancers.

(13) A desiccator is preferably used to remove water vapor from air drawn into the flow path by the patient.

(14) The pores are preferably placed in the porous membrane in an elongated oval or elongated rectangular
15 configuration. By configuring the pores in this manner and drawing air perpendicularly over the narrower dimension of the configuration it is possible to reduce the amount of collisions between particles and thereby avoid particles collision resulting in accumulation.

(15) The thickness of the membrane is preferably regulated in the range of 5 to 200 microns or more preferably 10 to 50 microns. Thinner membranes are useful in that less pressure is required to force formulation through the membrane. The membrane has a tensile strength
20 of 5,000 to 20,000, preferably 8,000 to 16,000 and more preferably 14,000 to 16,000 psi.

(16) The membrane is configured so as to have a convex configuration which protrudes into faster moving air created by the patient's inhalation or is designed to be
30 flexible so that it will assume a convex configuration when formulation is forced through the membrane.

(17) After the microprocessor is provided information with respect to above parameters or measurements a drug release point is chosen the
35 microprocessor will continually return to substantially the

- 77 -

same firing point at each drug delivery so as to obtain repeatability of dosing.

After drug has been delivered it is possible to discontinue any readings with respect to flow and/or
5 volume. However, it is preferable to continue readings with respect to both criteria after drug has been released. By continuing the readings the adequacy of this patient's particular drug delivery maneuver can be determined. All
10 of the events are recorded by the microprocessor. The recorded information can be provided to the caregiver for analysis. For example, the caregiver can determine if the patient correctly carried out the inhalation maneuver in order to correctly delivery drug and can determine if the patient's inhalation profile is effected by the drug.

15 The instant invention is shown and described herein in which is considered to be the most practical and preferred embodiments. It is recognized, however, that the departures may be made therefrom which are within the scope of the invention and that obvious modifications will occur
20 to one skilled in the art upon reading this disclosure.

- 78 -

CLAIMSWHAT IS CLAIMED IS:

- 1 1. An analgesic drug delivery device, comprising:
2 a channel having a first opening into which air
3 can be inhaled and a second opening from which a patient
4 can withdraw air;
5 a mechanism for applying physical force to
6 formulation of analgesic drug upon actuation; and
7 an air-heating device which adds energy to air
8 inhaled into the channel;
9 wherein the device is a hand-held self-
10 contained device having a total weight of 1 kilogram or
11 less.
- 1 2. The drug delivery device of claim 1, wherein
2 the mechanism for applying physical force to the
3 formulation is selected from this group consisting of a
4 piston and a vibration device.
- 1 3. The drug delivery device of claim 1, further
2 comprising:
3 a hygrometer for measuring ambient humidity, the
4 hygrometer supplying information used to determine an
5 amount of energy to be added by the air-heating device.

- 79 -

1 4. The device of claim 1, wherein the formulation
2 is present in a disposable container for use in aerosolized
3 delivery of drugs to the lungs, comprising:

4 a wall which is collapsible upon the application of
5 force;

6 an opening in the container which opening is covered
7 at least in part by a flexible porous membrane having pores
8 with a diameter in the range of about 0.25 to about 6.0
9 microns the membrane being sufficiently flexible such that
10 it will protrude outward in a convex configuration upon the
11 application of force; and

12 a formulation comprised of a pharmaceutically active
13 drug and a carrier which formulation is characterized by
14 its ability to form an aerosol of particles which can be
15 inhaled into a patient's lungs when the formulation is
16 moved through the pores of the membrane.

1 5. The device of claim 4, wherein the opening
2 forms an open channel leading from the opening to a
3 breakable seal beyond which is an area covered by the
4 flexible porous membrane.

1 6. The device of claim 4, wherein the pores have
2 a cross-sectional configuration with a small end opening of
3 0.25 to 6.0 microns in diameter and a large end opening of
4 2 to 20 times the diameter of the small end.

1 7. The device of claim 4, further comprising:
2 a means for measuring airflow through the channel
3 and determining inspiratory flow rate and inspiratory
4 volume; and
5 a means for determining a beginning point to force
6 formulation through the pores of the membrane based on real
7 time values of inspiratory flow rate and inspiratory
8 volume.

- 80 -

1 8. The device of claim 7, wherein the means for
2 measuring is mechanical.

1 9. The device of claim 7, wherein the means for
2 measuring is electronic.

1 10. The device of claim 4, wherein the porous
2 membrane includes from 10 to 10,000 pores over an area of
3 from about 0.1mm² to about 1cm².

1/7

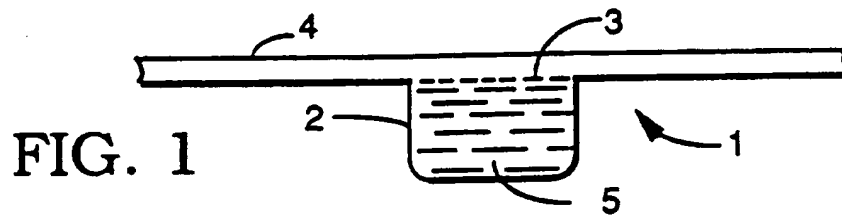

FIG. 1

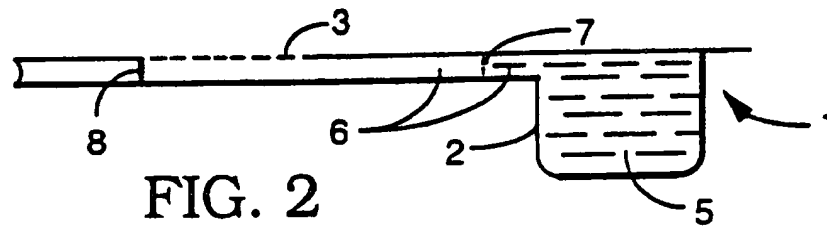

FIG. 2

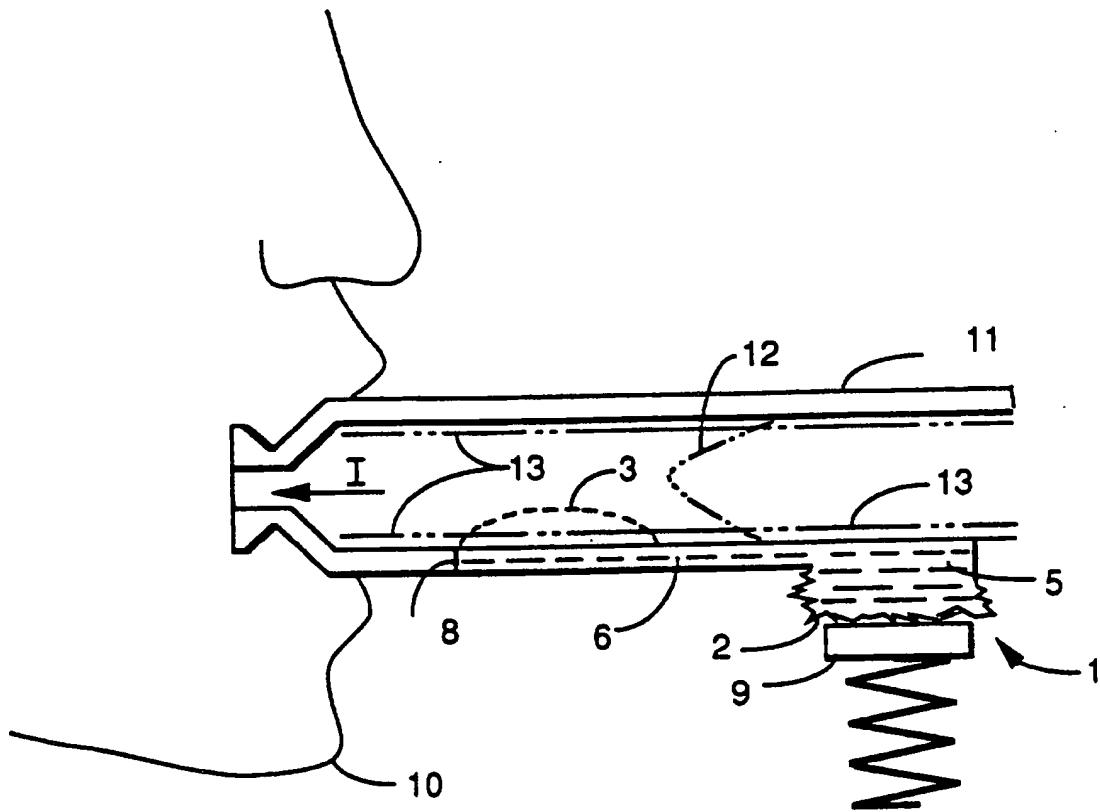

FIG. 3

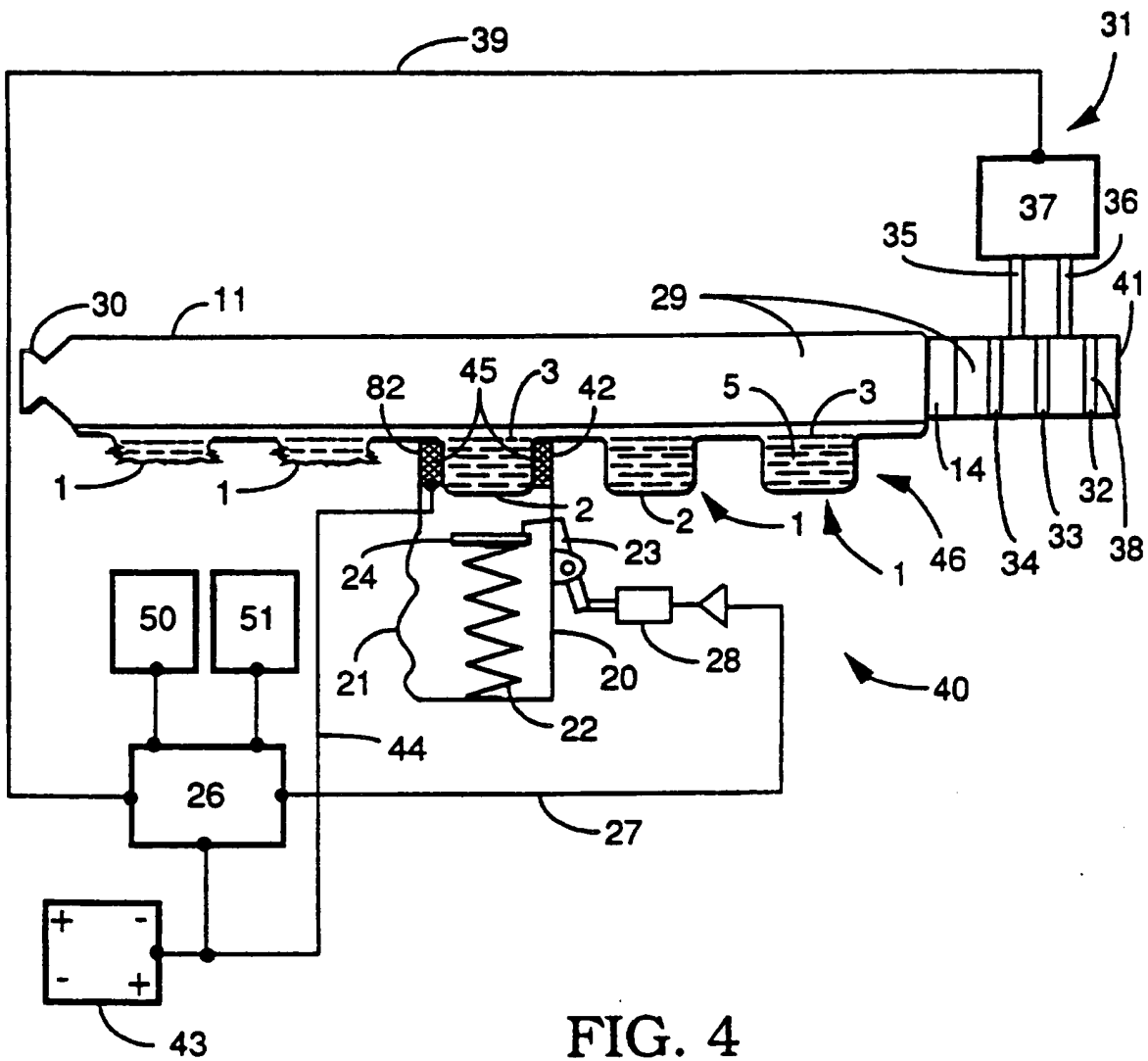

FIG. 4

3/7

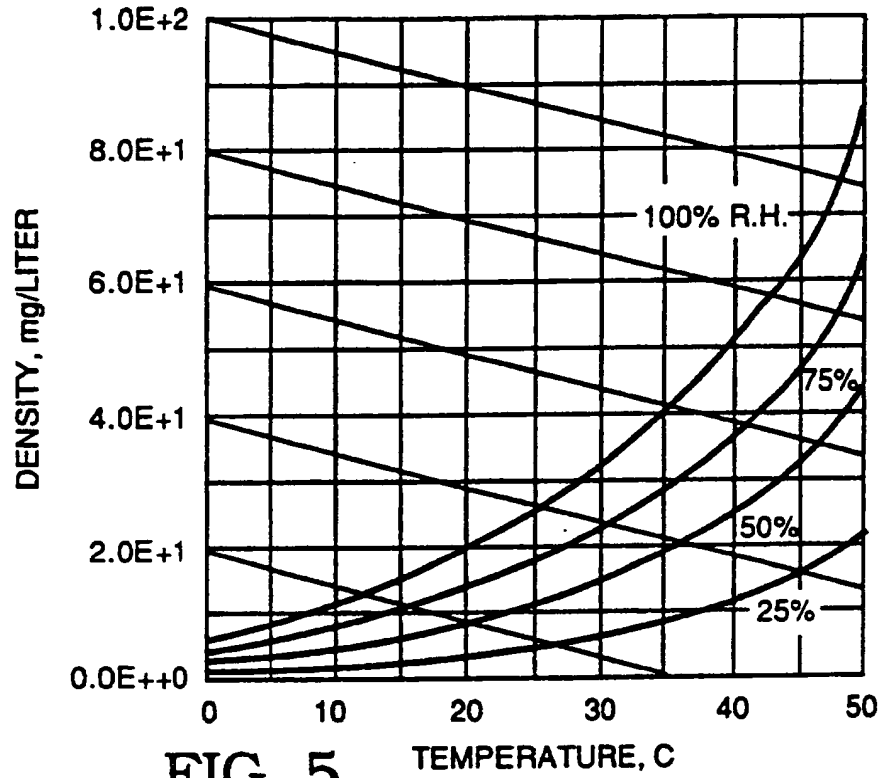

FIG. 5

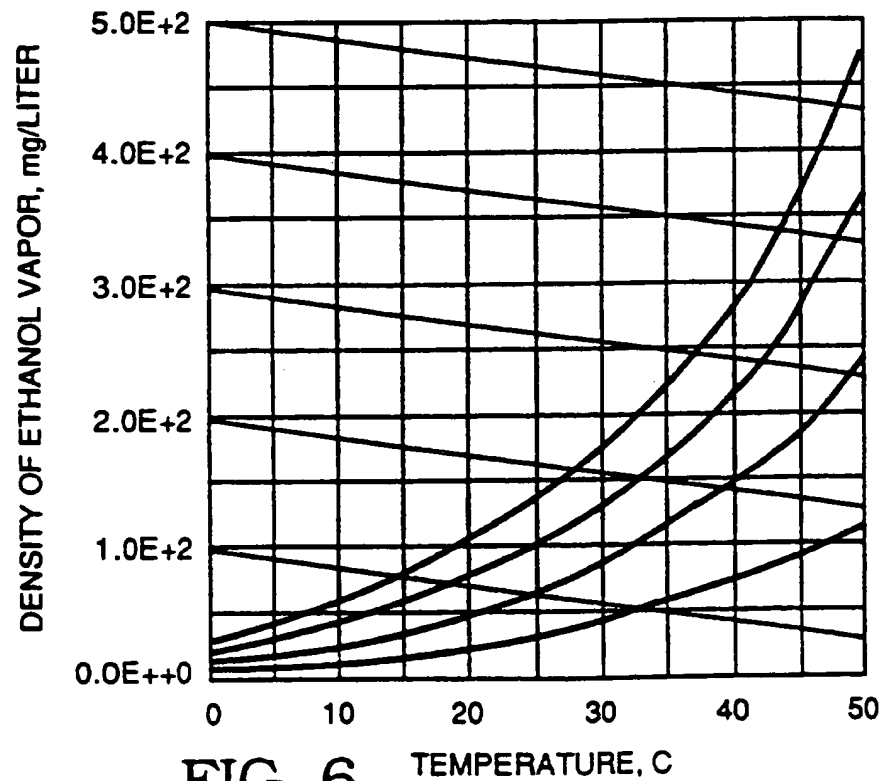

FIG. 6

4/7

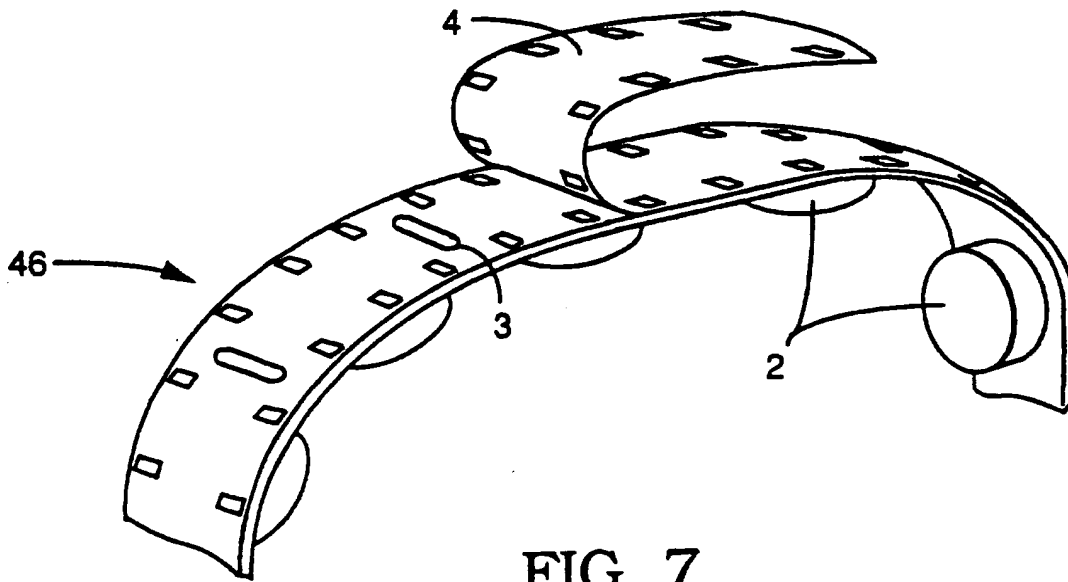

FIG. 7

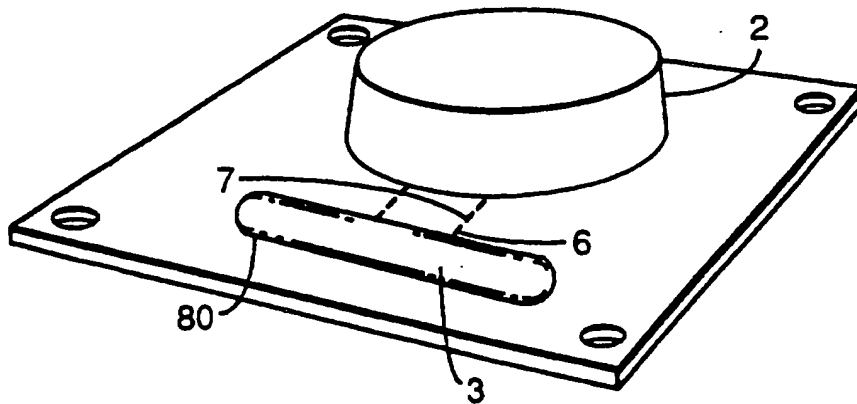

FIG. 8

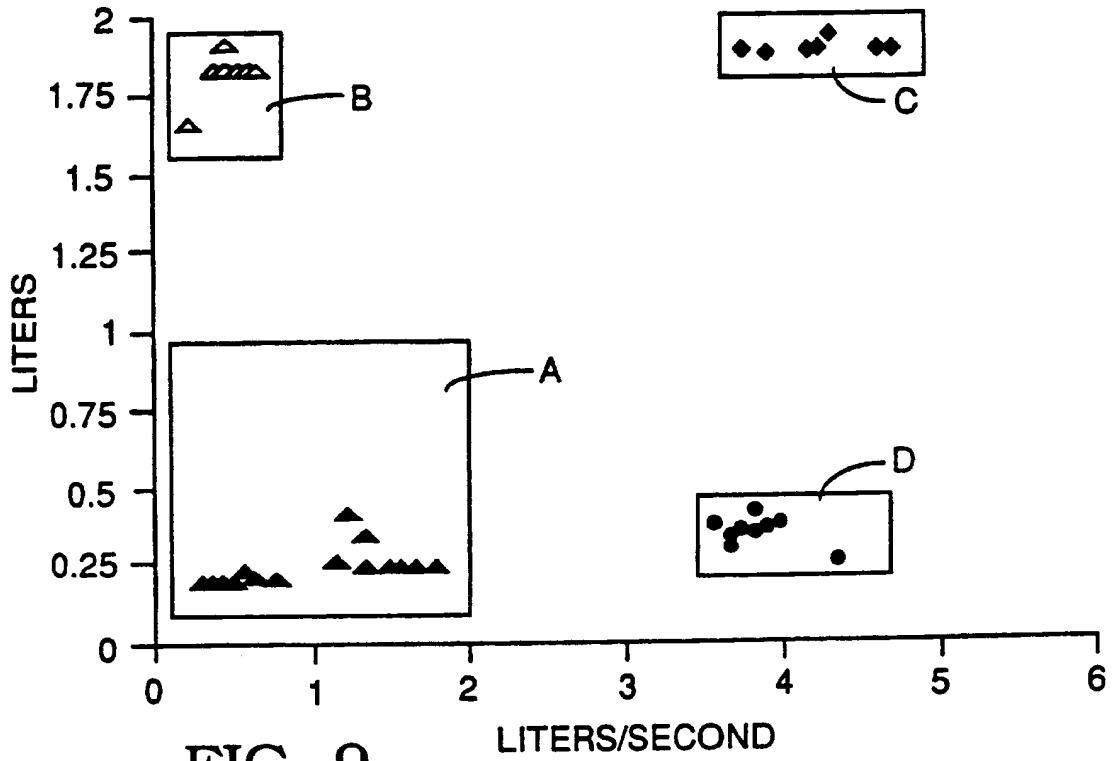

FIG. 9

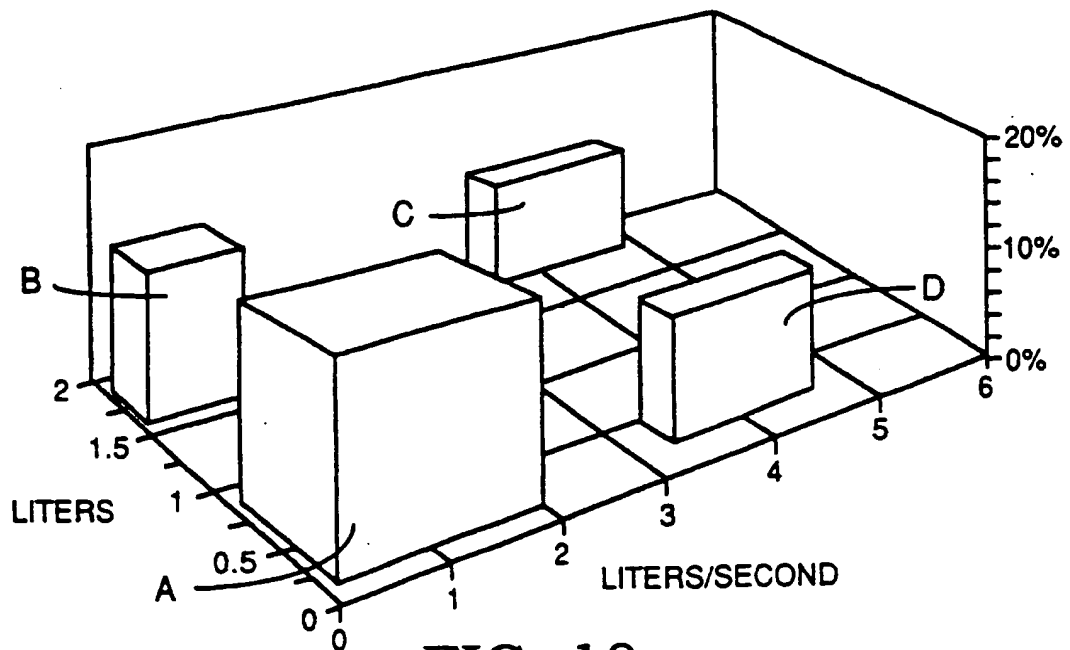

FIG. 10

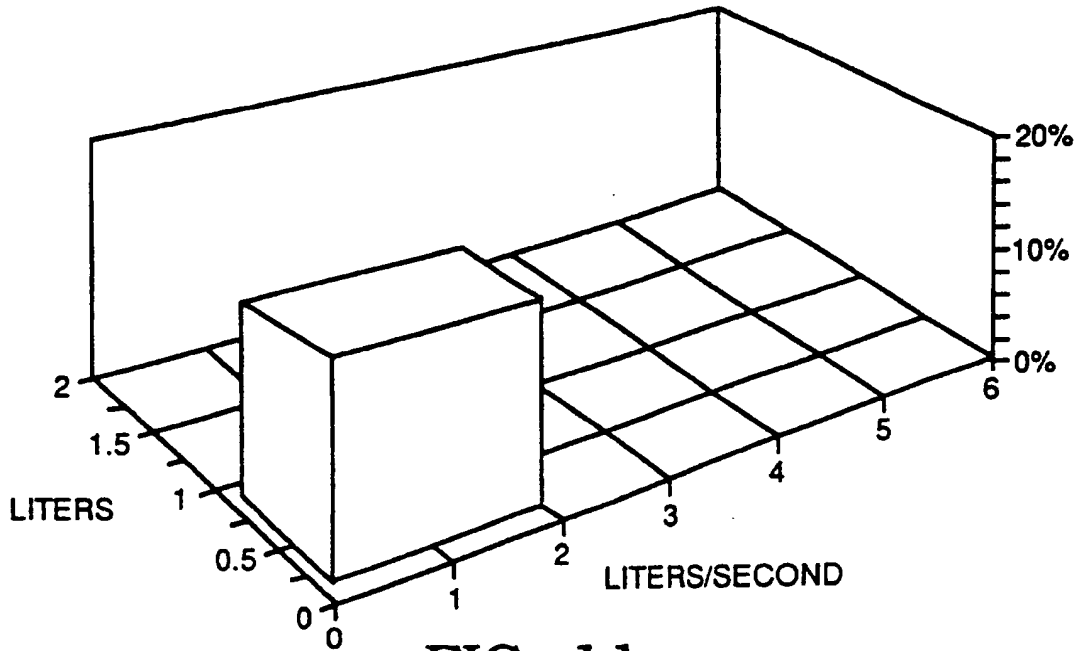

FIG. 11

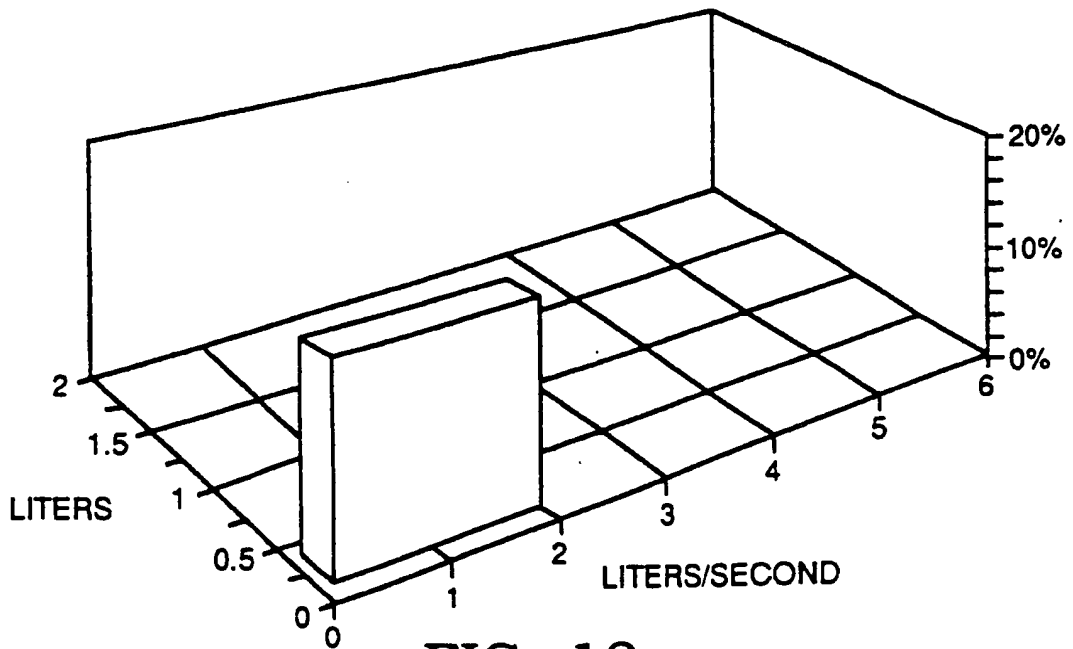

FIG. 12

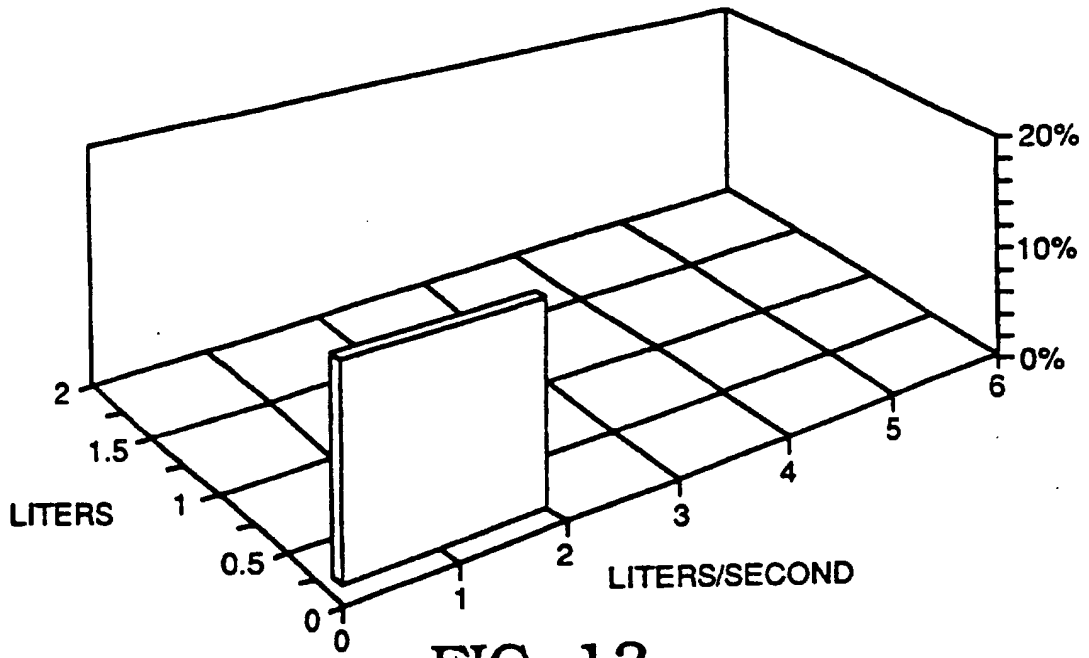

FIG. 13

INTERNATIONAL SEARCH REPORT

International application No.
PCT/US95/13910

A. CLASSIFICATION OF SUBJECT MATTER IPC(6) :A61M 11/00, 15/00; B65D 47/10 US CL :128/200.14, 203.12; 222/541.3, 541.4 According to International Patent Classification (IPC) or to both national classification and IPC				
B. FIELDS SEARCHED Minimum documentation searched (classification system followed by classification symbols) U.S. : U.S. CL. 128/200.14, 203.12; 222/541.3, 541.4 Documentation searched other than minimum documentation to the extent that such documents are included in the fields searched NONE Electronic data base consulted during the international search (name of data base and, where practicable, search terms used) NONE				
C. DOCUMENTS CONSIDERED TO BE RELEVANT				
Category*	Citation of document, with indication, where appropriate, of the relevant passages	Relevant to claim No.		
Y	US, A, 3,812,854 (MICHAELS ET AL.) 28 May 1974, see column 4 lines 5-34, column 5 lines 21-40, and column 6, lines 42-58.	1-10		
Y	US, A, 3,923,057 (CHALON) 02 December 1975, see Fig. 1.	1-10		
Y	US, A, 4,621,632 (BARTELS ET AL.) 11 November 1986, see Abstract.	1-10		
Y	US, A, 4,090,642 (BAKER) 23 May 1978, see Figs. 6 and 11.	4-10		
<input type="checkbox"/> Further documents are listed in the continuation of Box C. <input type="checkbox"/> See patent family annex.				
<table style="width: 100%; border: none;"> <tr> <td style="width: 50%; border: none;"> * Special categories of cited documents: *A* document defining the general state of the art which is not considered to be part of particular relevance *E* earlier document published on or after the international filing date *L* document which may throw doubts on priority claim(s) or which is cited to establish the publication date of another citation or other special reason (as specified) *O* document referring to an oral disclosure, use, exhibition or other means *P* document published prior to the international filing date but later than the priority date claimed </td> <td style="width: 50%; border: none;"> *T* later document published after the international filing date or priority date and not in conflict with the application but cited to understand the principle or theory underlying the invention *X* document of particular relevance; the claimed invention cannot be considered novel or cannot be considered to involve an inventive step when the document is taken alone *Y* document of particular relevance; the claimed invention cannot be considered to involve an inventive step when the document is combined with one or more other such documents, such combination being obvious to a person skilled in the art *Z* document member of the same patent family </td> </tr> </table>			* Special categories of cited documents: *A* document defining the general state of the art which is not considered to be part of particular relevance *E* earlier document published on or after the international filing date *L* document which may throw doubts on priority claim(s) or which is cited to establish the publication date of another citation or other special reason (as specified) *O* document referring to an oral disclosure, use, exhibition or other means *P* document published prior to the international filing date but later than the priority date claimed	*T* later document published after the international filing date or priority date and not in conflict with the application but cited to understand the principle or theory underlying the invention *X* document of particular relevance; the claimed invention cannot be considered novel or cannot be considered to involve an inventive step when the document is taken alone *Y* document of particular relevance; the claimed invention cannot be considered to involve an inventive step when the document is combined with one or more other such documents, such combination being obvious to a person skilled in the art *Z* document member of the same patent family
* Special categories of cited documents: *A* document defining the general state of the art which is not considered to be part of particular relevance *E* earlier document published on or after the international filing date *L* document which may throw doubts on priority claim(s) or which is cited to establish the publication date of another citation or other special reason (as specified) *O* document referring to an oral disclosure, use, exhibition or other means *P* document published prior to the international filing date but later than the priority date claimed	*T* later document published after the international filing date or priority date and not in conflict with the application but cited to understand the principle or theory underlying the invention *X* document of particular relevance; the claimed invention cannot be considered novel or cannot be considered to involve an inventive step when the document is taken alone *Y* document of particular relevance; the claimed invention cannot be considered to involve an inventive step when the document is combined with one or more other such documents, such combination being obvious to a person skilled in the art *Z* document member of the same patent family			
Date of the actual completion of the international search 06 JANUARY 1996		Date of mailing of the international search report <div style="font-size: 1.5em; font-weight: bold; text-align: center;">26 JAN 1996</div>		
Name and mailing address of the ISA/US Commissioner of Patents and Trademarks Box PCT Washington, D.C. 20231 Facsimile No. (703) 305-3230		Authorized officer <div style="text-align: center;"> AARON J. LEWIS Telephone No. (703) 308-0716 </div>		